

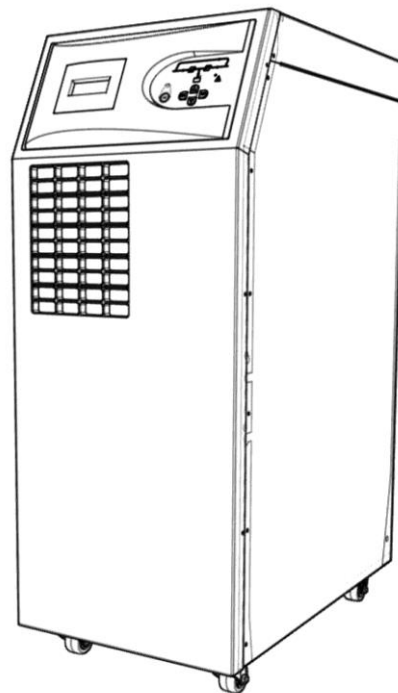

Smart-BX UPS

Models 10 - 20 KVA



User Manual

Smart-BX UPS

10 - 20 KVA

User Manual

AG-SD-109

Rev:0

FOREWORD

Thank you for choosing this product of **SMART-BX UPS 10-20kVA** range.

EnSmart Power is highly specialised in the development and production of uninterruptible power supplies (UPS). The UPS device described in this manual is designed and manufactured with care to guarantee uninterrupted power for your equipments and give you the best performance.

This manual contains detailed instructions for product use and installation.

For information on using and getting the best performance from your UPS, this manual must be stored in a safe place and CONSULTED BEFORE TAKING ANY ACTION ON THE UPS.

Please obey the instructions and all the warning stated in the manual or on the UPS. Do not run the UPS before finishing reading the safety and operation instructions.

Shipment

Carrying vehicles or handling accessories must have enough features and characteristics to carry UPS's weight.



DO NOT LIFT HEAVY DUTY WEIGHT WITHOUT HELP

1 Person	<18 kg (<40 lb)
2 People	18-32 kg (40-70 lb)
3 People	32-55 kg (70-120 lb)
Carrying vehicles or handling accessories	>55 kg (>120 lb)

Be more careful of sudden movements, especially when batteries are inside of cabinet.



CONTENTS

1 SAFETY and WARNINGS	1
1.1 Warnings.....	1
1.2 Clearance and Access	2
1.3 Storage	2
1.4 Shipment.....	2
2 PRODUCT DESCRIPTION	4
2.1 General Information	9
2.1.1 Static Transfer Switch.....	9
2.1.2 Battery Temperature Regulation.....	10
2.2 UPS's Operation Modes.....	10
2.2.1 Normal (Online) Mode	10
2.2.2 Battery (Stored) Mode	10
2.2.3 Bypass Mode	10
2.2.4 Automatic Restart Mode	11
2.2.5 Maintenance Mode	11
2.3 Battery Management.....	11
2.3.1 Advanced Level Functions (Automatic Battery Test).....	12
2.4 User Panel	13
2.4.1 Opening Screen.....	15
2.4.2 Main Menu	15
2.4.3 Navigating Through the Menus.....	15
2.4.4 Password Protected Menus.....	16
2.4.5 Control Menu	16
2.4.6 Status Menu.....	17
2.4.7 Setup Menu	18
2.4.8 Logging Menu	20
3 INSTALLATION	21
3.1 Single Module Installation	21
3.1.1 Warnings.....	21
3.1.2 Pre-Installation Check Up.....	22
3.1.3 Positioning	22
3.1.3.1 Positioning the UPS.....	22
3.1.3.2 Configuration of Internal Batteries	23

3.1.3.3 Placing External Batteries	24
3.1.4 Transportation Type of Cabinets	26
3.1.5 Mains, Load and Battery Connections	26
3.1.5.1 External Protections	26
3.1.5.2 Cable and Fuse Configuration	27
3.1.5.3 Cable Connections	27
3.1.5.4 Connecting Batteries	31
3.1.5.4.1 Internal Battery Installation Procedure and Connection	31
3.1.5.4.2 External Battery Installation Procedure and Connection	32
3.1.5.5 Control and Communication Cable Connections	34
3.2 Parallel Setup	35
4 OPERATION	39
4.1 Operation Procedure	39
4.1.1 Circuit Breakers	39
4.1.2 First Start-Up	39
4.1.3 Testing the Operation Modes of the UPS	41
4.1.3.1 Switching from Normal Mode to Battery Mode	41
4.1.3.2 Switching from Normal Mode to Static Bypass Mode	41
4.1.3.3 Switching from Static Bypass Mode to Normal Mode	42
4.1.3.4 Switching from Normal Mode to Maintenance Bypass Mode	42
4.1.4 Performing a Complete Shutdown	44
4.1.5 EPO (Emergency Power OFF)	45
4.1.6 RS232 Serial Communication Installation and Examination	45
5 EXPLANATIONS of LOGGING	46
6 TABLE of TECHNICAL SPECIFICATIONS	52
7 CONTACT INFORMATION	54

1 SAFETY AND WARNINGS

1.1 WARNINGS

This manual must definitely be read and understood before installing the UPS. The installation and first start-up can be performed only by an authorized **EnSmart Power** staff.

Installation and start-up by unauthorized persons may cause serious injury and/or result in death.

The UPS is designed to be used in continuous vertical position in fixed-positioned applications.



THE UPS MUST BE USED WITH GROUND CONNECTION.

Connect the ground cable before connecting the mains.

The ground leakage current may rise up to 0,4A.



THE UPS MUST BE DISCONNECTED FROM THE MAINS AND BATTERIES BEFORE SERVICING. ALSO WAIT FOR AT LEAST 5 MINUTES FOR THE DC BUS CAPACITORS TO DISCHARGE AFTER POWER OFF.

Service & Maintenance

All service and maintenance operations are performed internally. All parts of UPS can be serviced and replaced only by a trained personnel.



Performing regular protective maintenance at least once a year is recommended beginning from the first installation. (This service will be provided for a fee by authorized *EnSmart Power* staff.)



BATTERY VOLTAGE MAY RISE UP TO 450 VDC!

Battery voltages are in deadly levels (450Vdc). Batteries must not be touched except the trained staff.

Batteries certainly must not be thrown into fire. Regarding the topic of batteries which are dead and defected: The waste batteries must definitely not be thrown to nature. They must be delivered to **EnSmart Power** authorized technicians or to the foundations which are authorized for collecting waste batteries by the Ministry of Environment.

Fire extinguishing equipment must be kept nearby the UPS.

1.2 CLEARANCE AND ACCESS

Clearance

There exist no air inlet or outlet grilles on the sides of 10-20 kVA UPS. All air is taken through front and evacuated through fan grids on the back side. There must be 1 m clearance at least at front side and 1.2 m clearance at least at rear side of UPS. There should not be permanent or temporary use within the limits specified. Otherwise, the UPS's performance will decrease.

Access

Operator can reach the inside of UPS through front panel on our products in the range of 10-20 kVA. Therefore, enough area must be left for operator. Furthermore, the device can be accessed through the back side for service and maintenance. Thus, sufficient area must always be left in the back side in order that service staff can work.

1.3 STORAGE

UPS should be kept in a room or area where is protected from excessive moisture and heat before commissioning.



Unused batteries must be charged at regular intervals. This time interval is determined by the battery supplier. Charging batteries can be performed periodically by connecting to a proper mains for a while.

1.4 SHIPMENT

Carrying vehicles or handling accessories must have enough features and characteristics to carry UPS's weight.

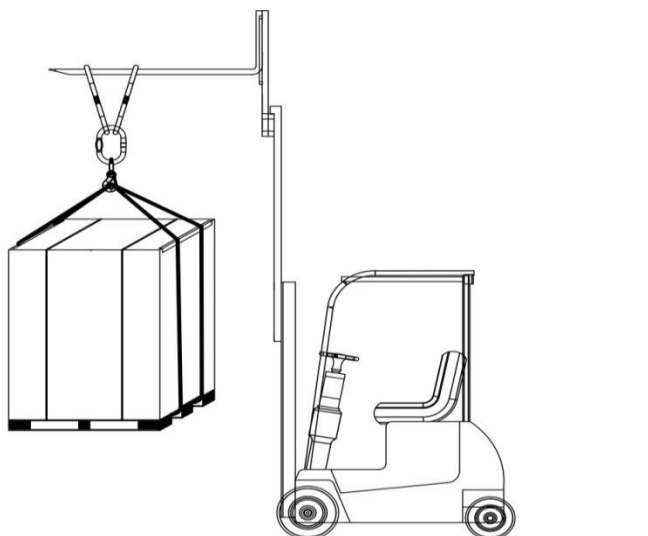

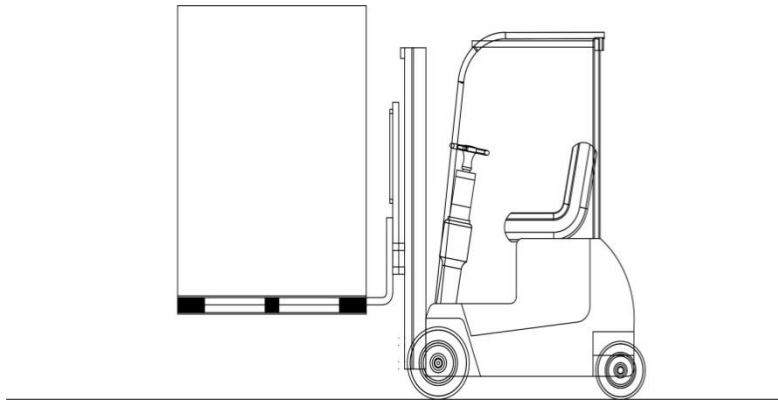

The cabinet is equipped with four wheels. By this means, it can be easily moved and placed. These wheels must only be used on smooth surfaces.

After the UPS has been placed on an appropriate position, front wheels must be locked. Back wheels are fixed. Be more careful of sudden movements, especially when batteries are inside of cabinet.

Move the UPS as rarely as possible.

2 PRODUCT DESCRIPTION

General View

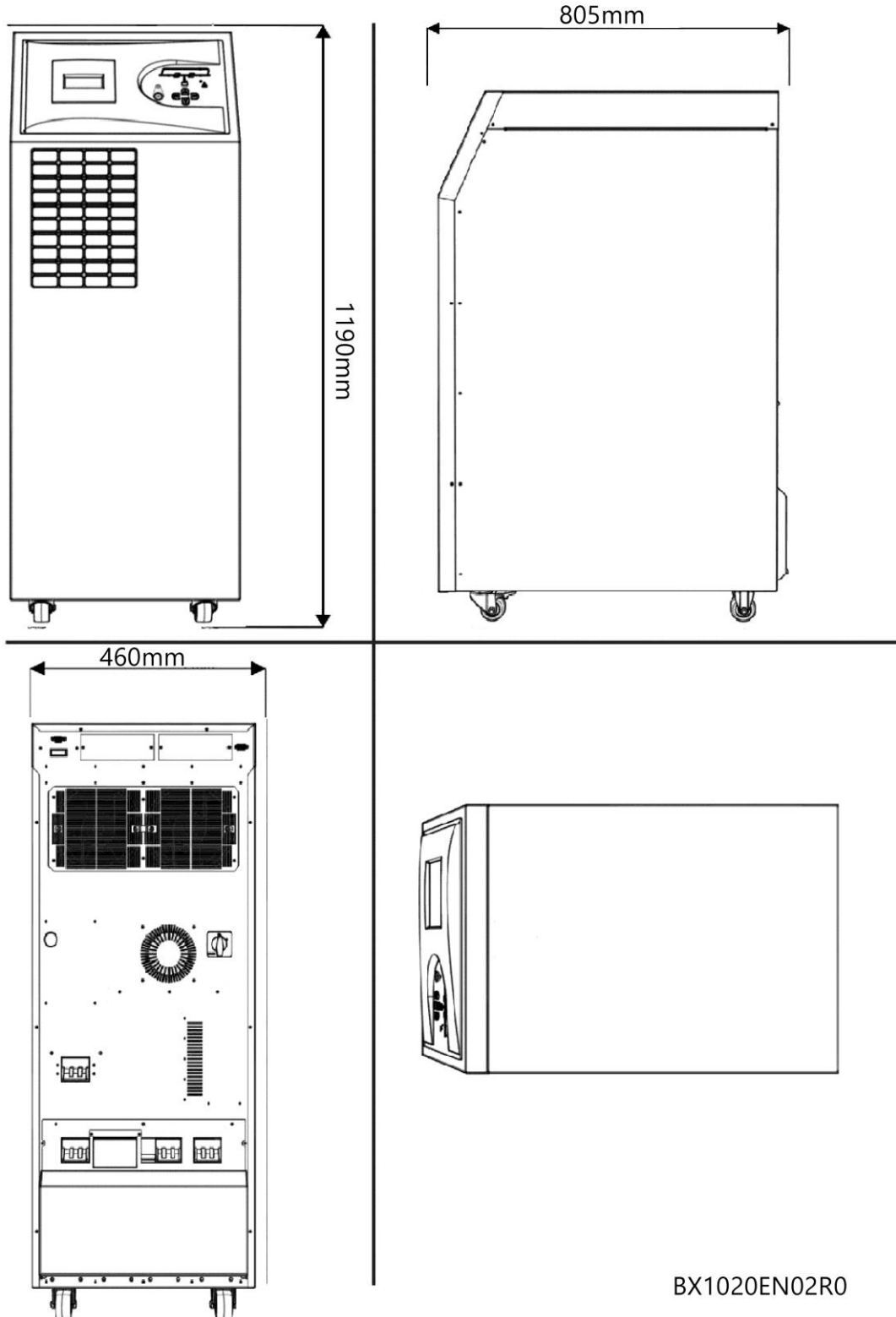

Front View

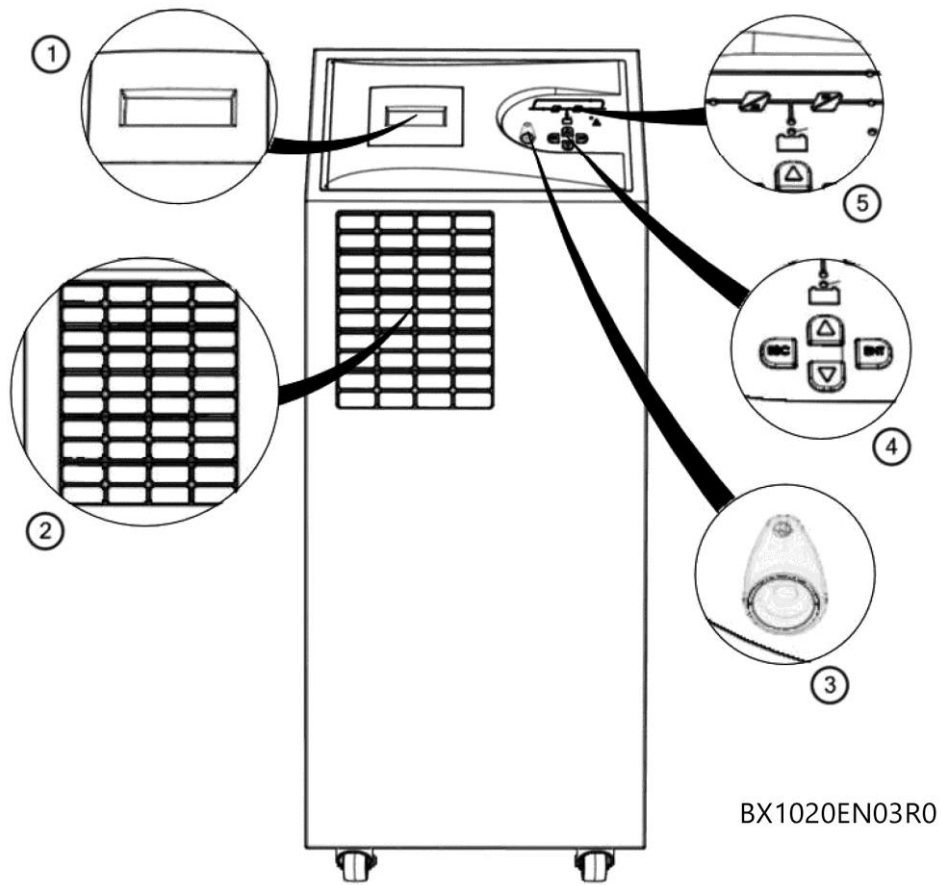

1	LCD Display
2	Fresh Air Vacuum Grid
3	EPO (Emergency Power Off) Button
4	Menu Navigation Keys
5	Mimic Diagram

Back View

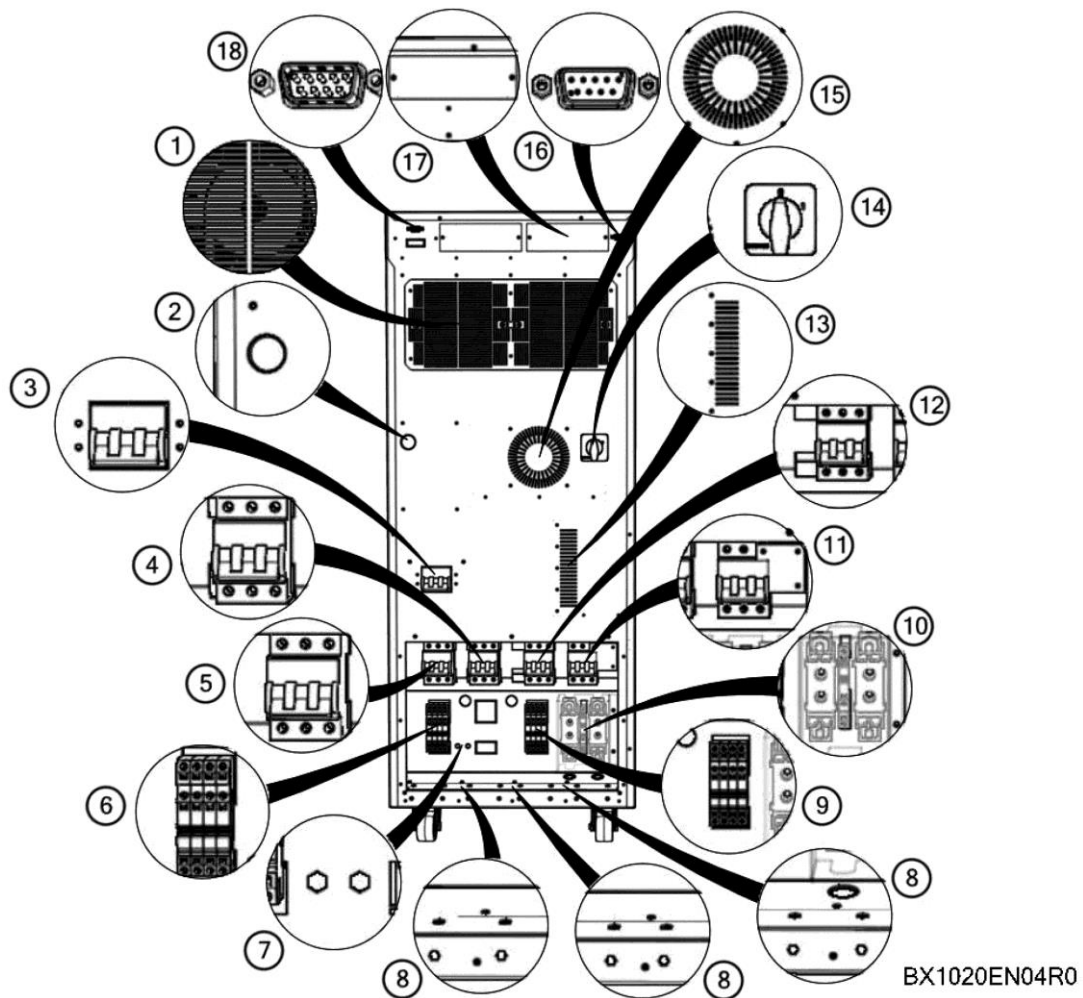

1	Rectifier/Charger-Inverter Cooling Fans
2	Bus Bar Charging Button
3	Optional External Bypass Switch
4	Maintenance Bypass Switch
5	Mains Switch

6	Mains Connecting Terminal
7	Ground Connection
8	Input-Output-Battery Cable Fixing Connectors
9	Output Connecting Terminal
10	Battery Fast Circuit Breakers and Connecting Terminals
11	Battery Commissioning Switch
12	Output Switch
13	Thyristor Hot Air Evacuation Channel
14	Optional Cold Start(Starting through battery) Switch
15	Winding Hot Air Evacuation Channel
16	RS232 Terminal for Communication Software
17	Optional Card Slots
18	Optional Parallel Connection Terminal

Electrical Connections

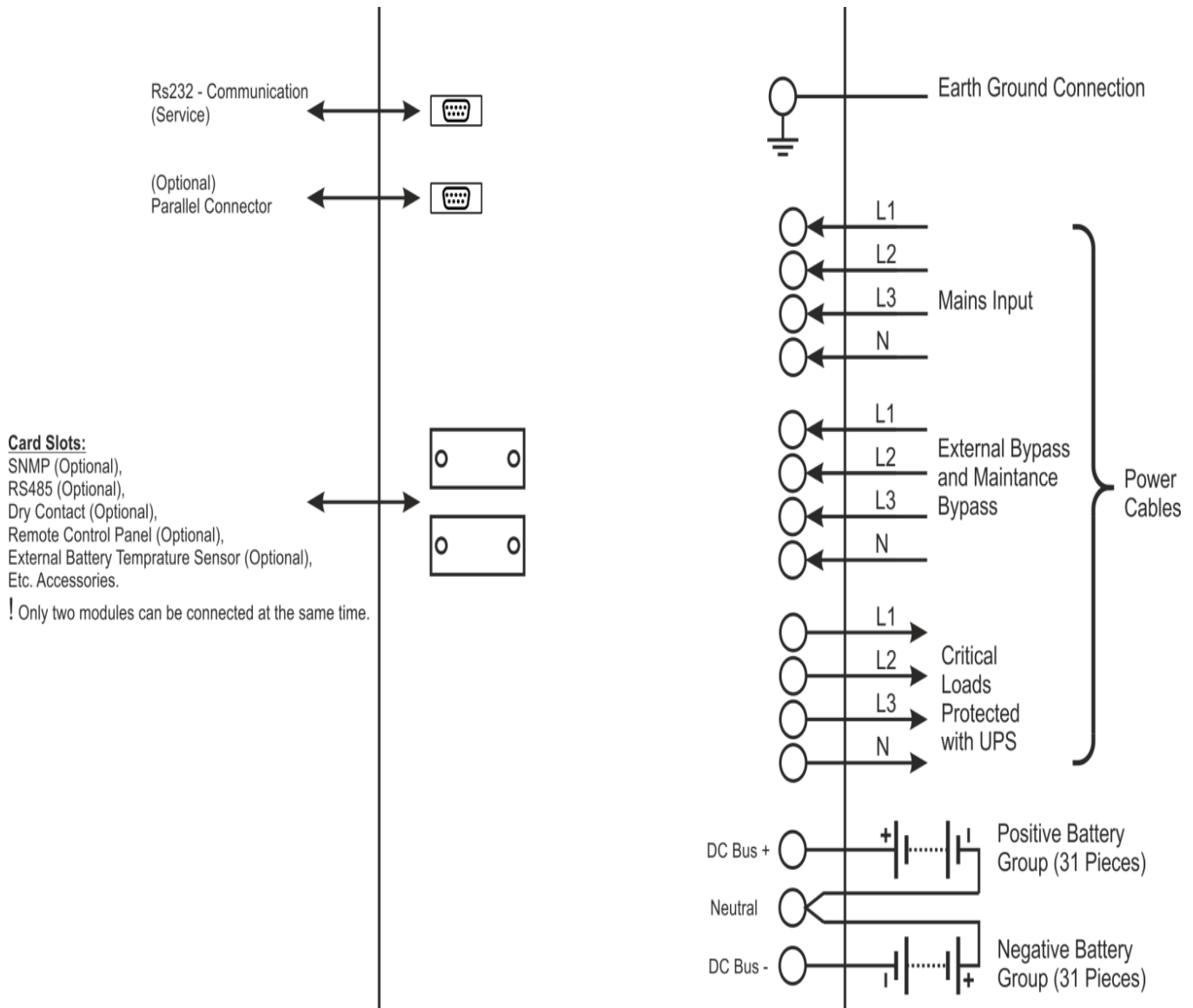

2.1 GENERAL INFORMATION

General operation topology of Smart-BX UPS 10-20kVA UPS can be recognized as follows:
The UPS is connected to the mains voltage through the CB1 breaker. After this energy has

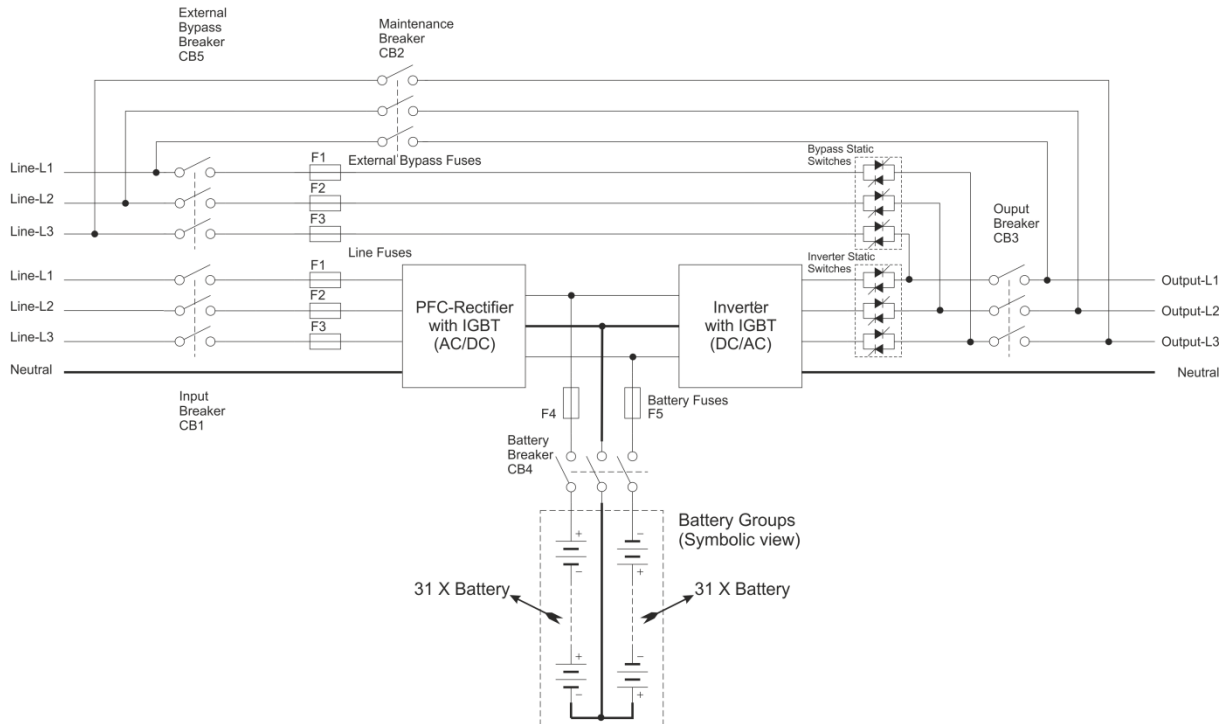

filled DC bus condensers, the rectifier operates. The rectifier converts the AC mains energy to DC voltage and charges the batteries in a controlled manner. When there exists no mains, sufficient level DC bus voltage is created, using battery voltage. DC bus voltage is converted to mains synchronized AC voltage by the inverter. This is a high quality voltage. Generated AC power are applied to the loads through the static semi-conductor transfer switches and output (load) circuit breakers.

When maintenance or repair are needed, before input (CB1) and output (CB3) circuit breakers are switched to open circuit (OFF), switch the UPS from normal mode to static bypass mode (see 4.1.3.2). Afterwards, the maintenance circuit breaker (CB2) is switched to closed circuit (ON). After that, output (CB3) and input (CB1) circuit breakers of the UPS are taken to the off position respectively.

2.1.1 Static Transfer Switch

Some blocks are named as static switches as can be seen above. These blocks consist of inverse parallel connected thyristors. These switches, which are under the control of the mainboard control unit, provides controlling of feeding the loads through either mains or inverters. The loads are fed through inverter during the normal operating mode. Therefore, inverter static switches are active if there is no problem with the system.

System provides the loads to be fed smooth and seamless by mains or inverter. In order to manage this process at minimum risk, UPS synchronizes the inverter output and mains bypass as the same phase and frequency. Therefore, inverter frequency is the same as mains frequency as long as it is acceptable within frequency limit.

User can switch between mains and inverter, using the front panel. Loads, operating from the mains with user instruction, will automatically undertake the load in the event that the mains cuts off or is out of tolerance.

2.1.2 Battery Temperature Regulation

Our products, in the range of 10-20 kVA, have spaces to place internal battery in their cabinets. There exists temperature sensor in external battery cabinets. Temperature of these batteries is measured by this “temperature sensor”. The UPS adjusts battery charge parameters according to the information of the detected temperature. These parameters can easily be adjusted via LCD in the system or TELNET interface by authorized staff.

This sensor and the UPS regulates charge parameters in the same way. In this case, we advise you to order “**External Battery Temperature Sensor Kit**” for temperature detection of the UPS.

2.2 UPS OPERATION MODES

Smart-BX UPS 10-20kVA UPS's on-line and has a double loop structure. Our products operate in the following modes:

- Normal (Online) Mode
- Battery Mode
- Bypass Mode
- Auto Restart Mode
- Maintenance Mode

2.2.1 Normal (Online) Mode

In this mode, UPS supplies the load through the inverters. Rectifier unit is fed by the AC mains. Inverter and battery charger units can be fed by the generated DC supply.

2.2.2 Battery (Stored) Mode

Due to any failure of the mains, while the UPS feeds the critical loads through inverter, this energy can be supplied from the batteries.

2.2.3 Bypass Mode

On account of UPS overload or any problem on inverter, no qualified AC output is produced and if bypass voltage and frequency are in tolerance, loads are then fed through bypass source. UPS switches from inverter to AC source via static transfer switches without any interruption. The inverter source and mains must be synchronized in order to manage this switching processes without any problem. If inverter output and mains are not synchronized, this switching may take up to 15 msec. varying according to load type.

2.2.4 Automatic Restart Mode

In case of any failure of the mains, the UPS will continue feeding the critical loads until the batteries reaches the end of discharge voltage level. The UPS will go on working until the batteries are drained, and then will shut down. After the mains conditions gets back to normal, the UPS automatically starts to operate in a period to be determined. In this case, the UPS continues to operate in normal mode as long as the mains values are in desired criteria. In the Smart-BX UPS 10-20kVA UPS, this feature is not activated in factory settings.

2.2.5 Maintenance Mode

The UPS is equipped with a specific protection switch in order to keep the loads powered during maintenance. This switch is designed so as to handle UPS loads completely.

2.3 BATTERY MANAGEMENT

Constant Charge Current

Constant current as 1/10 rate of the battery capacity is applied to battery, until the battery reaches the float charge voltage.

Float Charge

Depending on the battery discharge current, 1/3 of the energy of the battery is charged at this level. Owing to this level, batteries are kept ready for use at the highest capacity. For lead-acid batteries, this voltage varies between the values of 2.2-2.35 V/cell. This voltage may differ slightly due to temperature adaptation. Option of setting this coefficient is provided with our UPS. If the temperature sensor is used, it is recommended to use.

Deep Discharge Protection

While the system is operating in the battery mode, if battery voltage has dropped below the deep discharge voltage level, the UPS shuts down and stops absorbing energy from the batteries. This value varies between 1.6-1.75 V/cell for Lead-Acid batteries, and between 0.9-1.1 V / cell for Ni-Cd batteries.

Low Battery Warning Level

While the system operates in spare, in other words, battery mode, if the battery capacity drops below its 40% value with actual loads, it will give audible and visible alarms. This value can be adjusted by user between 20%-70%.

2.3.1 Advanced Level Functions (Automatic Battery Test)

The auto battery test automatically discharges 10% of the battery existing capacity in a certain period defined (default is 90 days). The period between two tests can be adjusted by user between 30-360 days. At the end of the test, one of these two status, “**good or replace**” is determined.



At the end of this test, if batteries are reported as “replace”, then the batteries are completely drained after the test. In this case, loads can remain unpowered in case of mains power off.

This test can automatically be started by command from front panel monitor, via telnet interface, via RS232 smart communication or via UPSMAN (SNMP, see the options).

As a result of all these tests, it is checked whether the batteries that are presently used can supply the minimum needs of loads in case of the first power-off or not. It is recommended that test results be checked at regular intervals.

2.4 USER PANEL

User panel consists of mimic diagram, LCD screen, EPO button and menu keys. The UPS can be controlled via this panel.

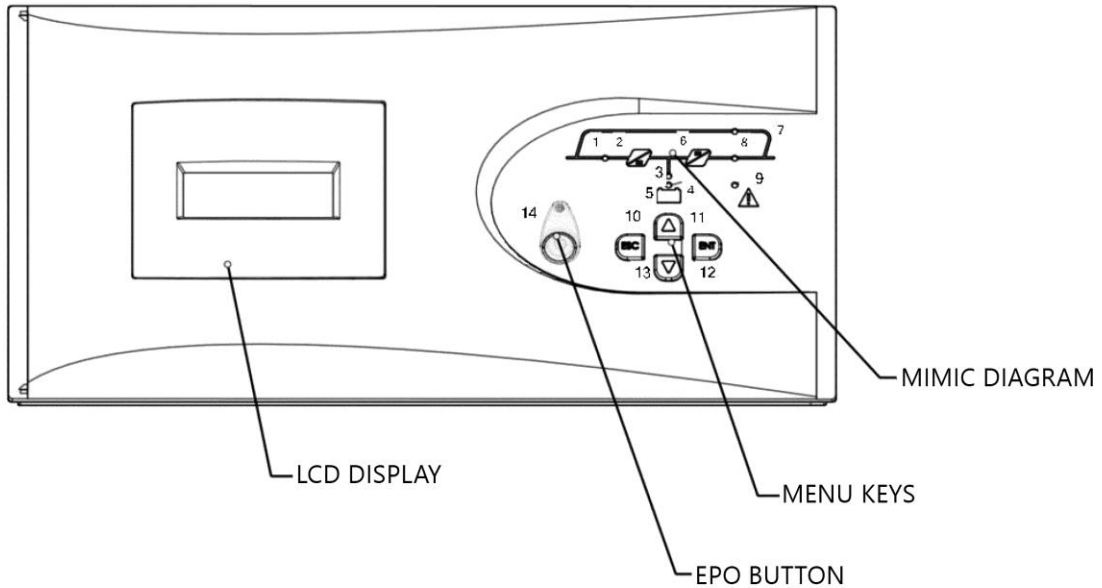

1	Rectifier indicator LED <i>It constantly illuminates when rectifier works.</i>
2	AC/DC module (Rectifier)
3	Battery discharge indicator LED <i>It illuminates in battery mode and flashes when UPS is started up through batteries.</i>
4	Battery charge indicator LED <i>It illuminates while the batteries are charged.</i>
5	Battery module
6	DC/AC module (Inverter)
7	Bypass static switch indicator LED <i>It illuminates while the loads are fed through bypass line.</i>
8	Inverter static switch indicator LED <i>It illuminates when the load is fed by the inverter.</i>
9	Alarm/Warning indicator LED
10-13	Menu keys
14	EPO Button

Menu Flow Chart

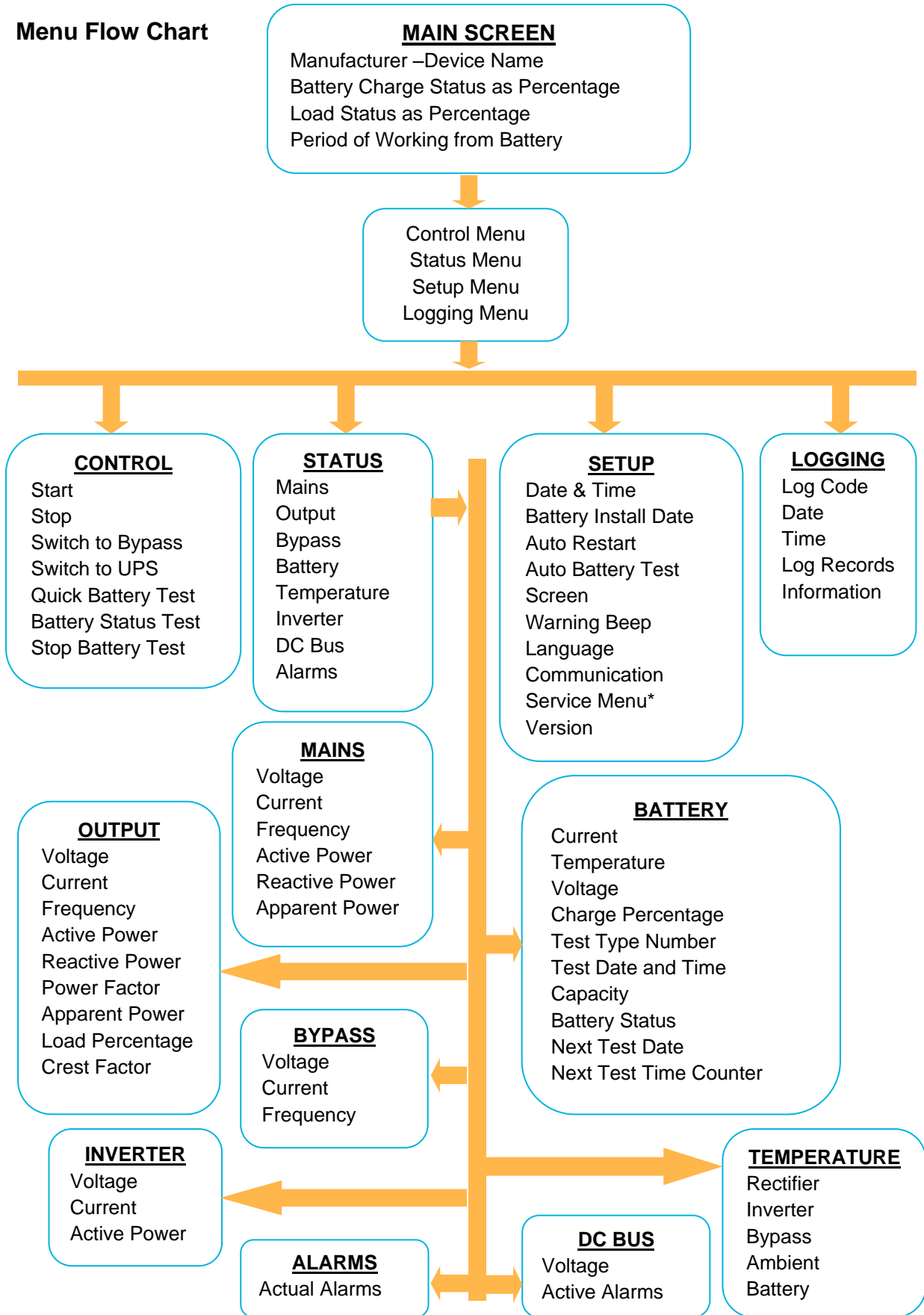

* Detailed service menu can only be opened by the authorized service staff.

2.4.1 Opening Screen

When the front panel monitor is turned on, firstly opening screen is observed. Model name, charge status, load status and remaining back-up time are displayed. In case of any alarm case, alarms are shown as scrolling text in the first line. If no button is pressed for 5 minutes, system returns to the opening screen.

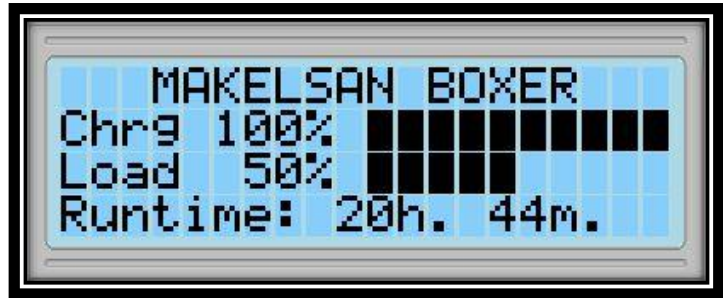

2.4.2 Main Menu

Switch from opening screen to the main menu through **ENT** button.



2.4.3 Navigating Through the Menus

Press **UP/DOWN** keys to move the cursor arrow in the screen. Open a sub-menu with **ENT** button, go back to the previous menu with **ESC** button. Control sub-menu is shown on left. Some menus consist of more than one page. Switch among the pages with **UP/DOWN** buttons.



Some menus have changeable options like ON/OFF, durations or quantities. To change setup in such menus, choose variable with **ENT**, set new value with **UP/DOWN** buttons and save it with **ENT** button. Cancel with **ESC** button.

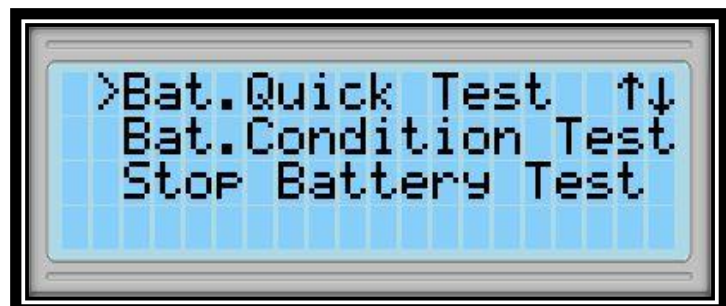

2.4.4 Password Protected Menus

Some menus such as the control menu are password protected. To enter password choose each digit with **UP/DOWN** buttons and confirm with **ENT** button.

User level password is: 0000



2.4.5 Control Menu

The followings can be done in the control menu:

- | | |
|-----------------------------|-------------------------------|
| ➤ Start | Start the UPS. |
| ➤ Stop | Stop the UPS. |
| ➤ Switch to BYPASS | Switch to static BYPASS mode. |
| ➤ Switch to UPS | Switch to online mode. |
| ➤ Bat. Quick Test | Start the quick battery test. |
| ➤ Bat. Capacity Test | Start the deep battery test. |
| ➤ Stop Battery Test | Stop the battery test. |

Battery status test, drains the 10% of battery energy and reports batteries which has more capacity than 10% as **“Good”**, less capacity than 10% as **“Replace”** according to the test results.

After the device is started and every 24 hours, it automatically performs a quick battery test, if test counter value is zero.

Note: Batteries must have been fully charged and kept in floating situation for 1 hour before performing the quick battery test.

Batteries must have been fully charged and kept in floating situation for 5 hour before performing the battery status test.

Battery tests are performed by directing the power to the mains, independently from the loads. If the mains values gets out of limits during the test, test is cancelled.

Following **Status> Battery** menu, how many minutes left to start the test can be observed.

If **“Stop Battery Test”** is chosen from the menu, the UPS cancels the battery test and goes back to the previous operating state.



2.4.6 Status Menu

The mains, output, bypass, battery, inverter, DC bus and alarms can be displayed on this menu.



Mains

VP, A Hz
KW, KVA, PF
Pt, St, VL

Voltage (phase-neutral), current and frequency of each phase.
Active power, reactive power and power factor of each phase.
Total active power and apparent power, voltage of each phase (phase-phase).

Output

VP, A, Hz
KW, KVA, PF
Pt, St, %L

Voltage (phase-neutral), current and frequency of each phase.
Active power, reactive power and power factor of each phase.
Total active power, total apparent power and load, in percentage, of each phase.

VL, CF

Voltage of each phase (phase-neutral) and crest factor.

Bypass

VP, A Hz
VL

Voltage (phase-neutral), current and frequency of each phase.
Voltage of each phase (phase-phase).

Battery

A, °C, V, Charge%
SXXXX, DD/MM/YY,
SS: DD, Capacity, Status
Next Test, time

Charge flow, temperature, voltage and charge percentage.
Test type number, date and time. Batter capacity and status.
Next test date and count down for battery test in floating status.

Temperature

°C, °C, °C, °C, °C

Rectifier, inverter, Bypass, ambient and battery temperatures.

Inverter

VP, A, KW

Voltage (phase-neutral), current and active powers of each phase.

DC Bus

P, N
Alarms

Positive bus voltage, Negative bus voltage.
Active UPS alarms.

2.4.7 Setup Menu

The following adjustments can be performed via setup menu:

Date & Time

To set date and time, use up and down keys to choose the variable you want to set and press **ENT**.



Set the value via arrow buttons and press **ENT** button again.



Battery Installation Date

When new batteries are installed, set the battery install date via this menu.



Automatic Restart

In battery mode, the device operates until batteries discharge and then shuts down. Auto-restart can be used to restart the UPS automatically when the mains gets back into limit values. Open/close auto restart via the option of ON/OFF and determine how much time after the device will be started after the mains is normal.



Automatic Battery Test

Use this menu to open/close automatic battery test and to set the period (repeat period for the regular test) independently from user.



Screen

Change the screen contrast setting to make it more visible on different environmental conditions.

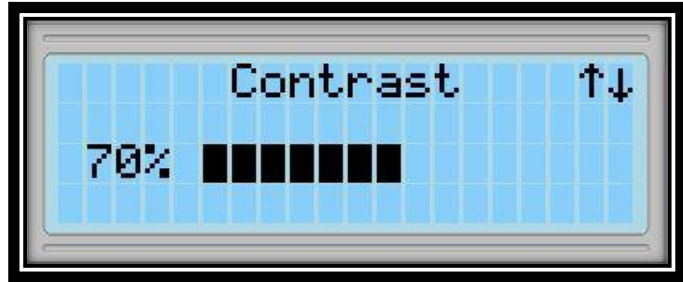
**Beeper**

Turn the beeper sound on/off.

**Language**

Set the menu language.

**Communication**

Set the protocol for the RS232 connection. The options are SEC and Telnet.

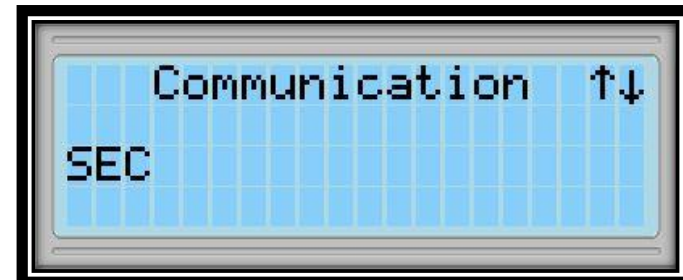
**Service Menu**

Service menu is password protected. It can only be accessed by authorized service staff.



Version

Inverter, rectifier, CPLD, front panel software version and UPS serial no, device apparent power (KVA), nominal output voltage (phase-neutral), nominal output frequency (Hz); parallel battery handle number x series battery handle number and battery capacity set on the UPS can be accessed through the version menu.



2.4.8 Logging Menu

The last 500 logs can be observed in the logging menu.

While observing any of the logs, if ENT button is pressed, all details regarding the moment of the event (mains, battery, bypass, output values, alarms etc.) can be seen.

Older/actual logs can be observed, using **UP/DOWN** buttons.



3 INSTALLATION

3.1 SINGLE MODULE INSTALLATION

In this section, warnings which you must follow and the checks which you must perform before starting-up the device are stated. Additionally, you can find information concerning the points you must pay attention to during carrying style for cabinets, positioning and connections.

3.1.1 Warnings



The UPS must be installed by the personnel approved by *ENSMART POWER*. Warranty is not valid for the devices installed by unauthorized personnel.



BATTERY HAZARD!

In some models, during operation of battery and the UPS together, there may exist battery terminal voltages reaching up to 450 VDC.

Precautions must be taken in order to protect eyes against electrical arcs that can result from contacts.

ESD-protected rubber gloves should be used.

Batteries discharging or leaking must not be used, if any, it must be replaced. Uninstalled batteries must be kept, carried and transferred to destruction points safely.

In case of skin contact with elector liquid, immediately rinse the exposed skin part with water.

Operator must remove any dangerous accessories such as ring, watch etc. before working on the device.

The product needs three phase and four cable (+ground) supply system for input. Type of this supply system conforms to IEC60364-3 standards. The devices have transformers which have ability to optionally convert from three cable to four cable system. Provided that IT AC power distribution will be installed, 4 pole-circuit breaker must be used. More detailed explanations concerning the topic can be found in the standard named as IEC60364-3.

3.1.2 Pre-Installation Check Up

Before installing the UPS product, the following checks should be carried on. These are the first and important steps in the operation of the product correctly.

- Definitely check whether or not any damage was done to internal and external structures of the UPS, accessories and batteries during transportation or shipment. Report any damages before receiving.
- Make sure that the product is the right model. Check whether the label behind the device matches with the product ordered or not.

3.1.3 Positioning

The UPS and the batteries are designed for indoor use, and must be placed on a clean area with cool air flow.

3.1.3.1 Positioning the UPS

For the Boxer 10-20 KVA Series, fresh and cool air enters the device from the front side and goes out through the fans on the back side of the device. Air entrance and exit points should never be closed. It must be positioned on a place where is protected from water or similar liquid contact risks.

If the area is very dusty, filters optional provided must be used. Usage of these filters must be done according to the relevant instructions.

The UPS is structurally a losing-energy system. Lost energy occurs as temperature. How forced air cooling system is needed is provided in the following table. Using the table, what capacity of air conditioned should be used to cool the place where the UPS is can be determined.

Device	BTU/h amount for cooling	Estimated BTU/h value For 100%Bridge Load (Non-Linear Load) Operation
10KVA	2,663	3,196
15KVA	3,790	4,548
20KVA	3,892	4,670

3.1.3.2 Configuration of Internal Batteries

The 10-20 kVA UPS can be configured through 64 4,5Ah, 7Ah or 9Ah standard batteries as seen in the following table:

Smart-BX UPS Internal Battery Usage			
Device Power (KVA)	10	15	20
Series Battery Number	31	31	31
Battery Group	2	2	2
Total Battery Number	62	62	62
I _{bat.max} @V _{bat_cutoff} (A)	12,5	18,8	25,1
Recommended Internal Fuse (A)	20	32	40
Recommended Rear Cover Fuse(A)	20	32	40

*** These cells are battery configurations recommended.**

* Type being able to perform fast and semi-conductor protection is used in battery fuses.

Positioning forms of 7/9 Ah and 4, 5 Ah batteries inside the UPS can be seen in detail in the following figures:

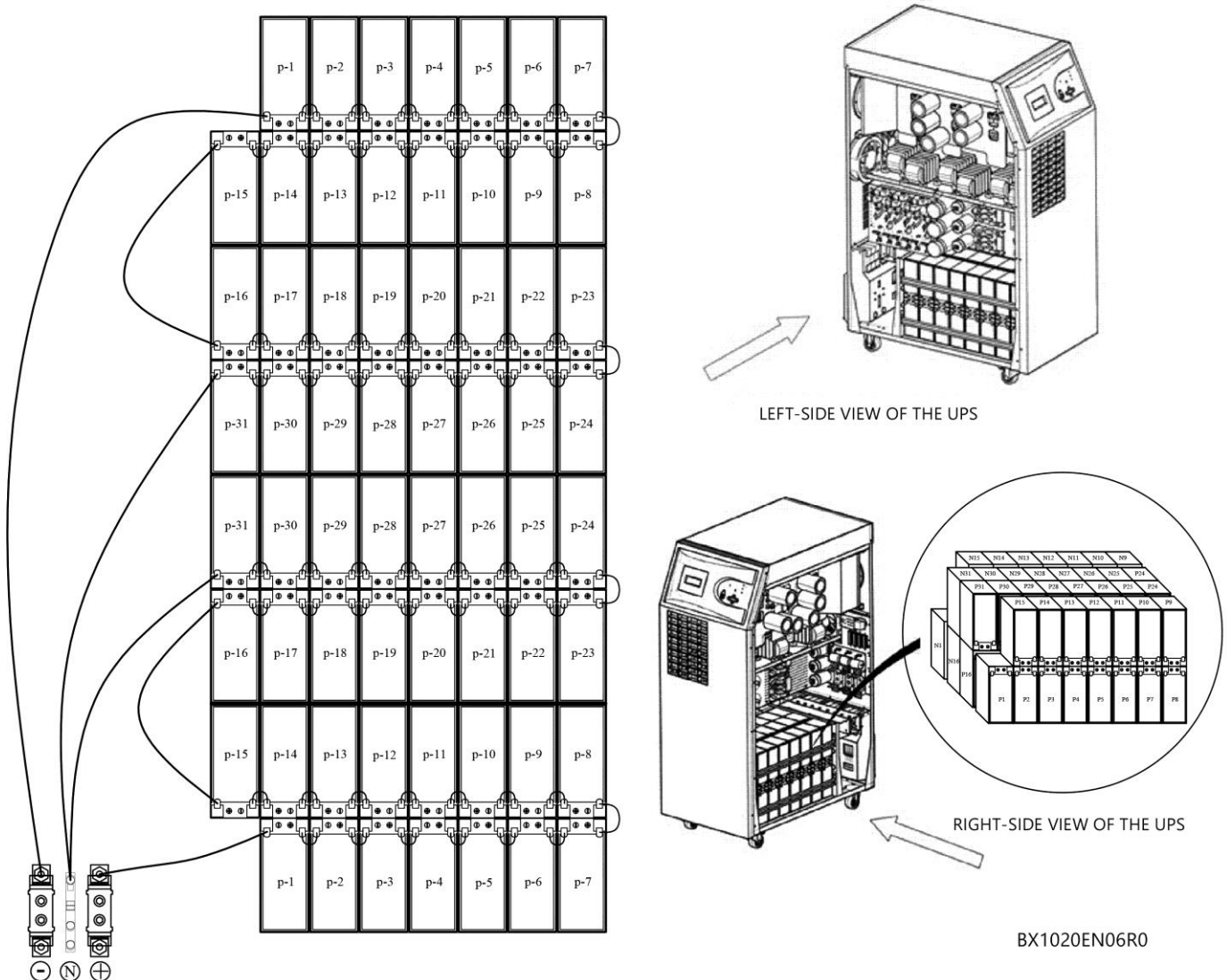

BX1020EN06R0

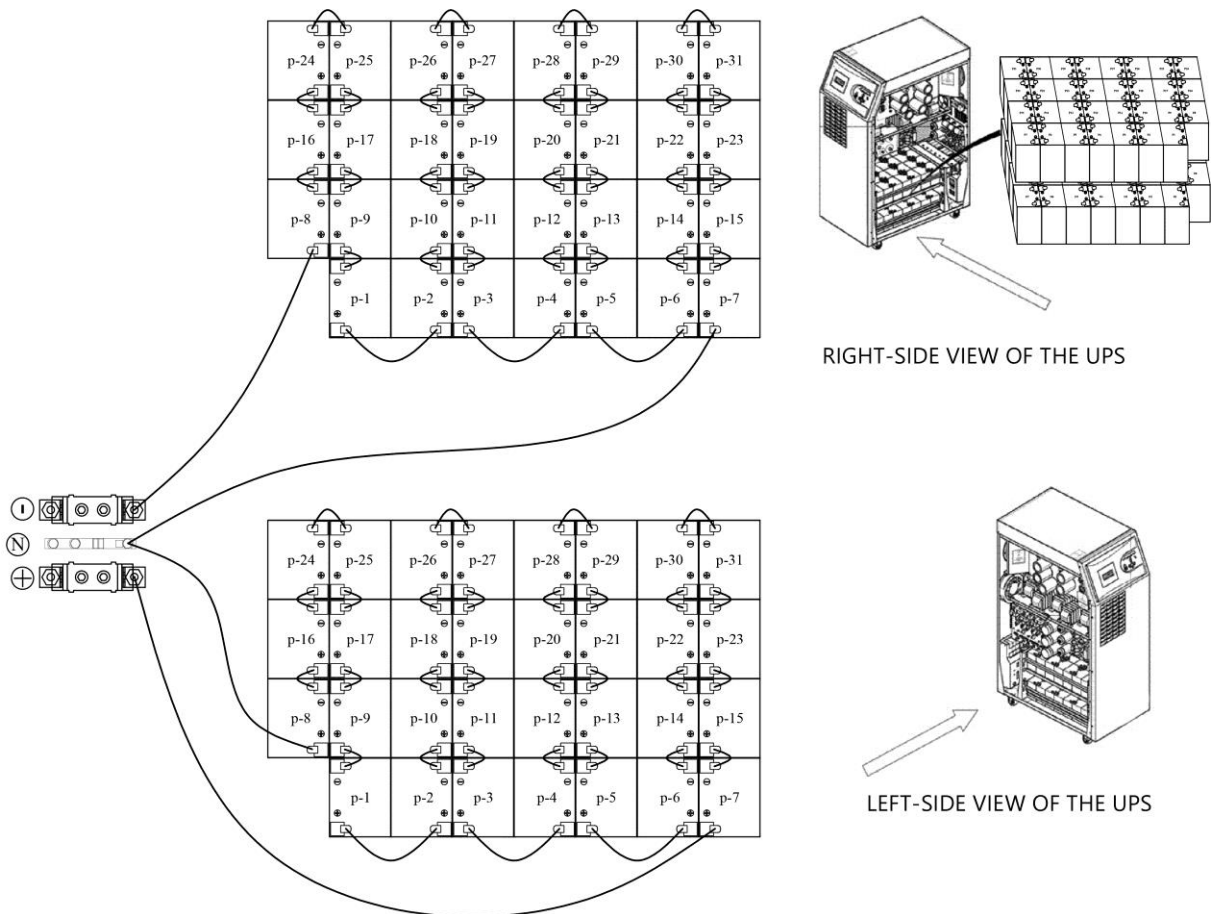

3.1.3.3 Placing External Batteries

Batteries should be mounted in an environment where the temperature is consistent and even over the whole battery. Temperature is a major factor directly affecting the battery life and capacity. In general, battery manufacturers recommend that batteries be used in 20-25 °C. Furthermore, battery manufacturer companies indicate the performance of batteries according to the said temperature range. If the temperature exceeds the said range, the life of the battery will decrease. On the contrary, again if the temperature drops the said range, the capacity of the battery will seriously decline. Therefore, expected time will not be obtained during back up. As a result, keep batteries away from heat sources and serious air flows. Pay attention to the said factors and be careful about and observe the following points in terms of external connections of the batteries:

- Keep batteries away from main heat sources.
- Keep batteries away from serious air flows.
- Keep batteries away from the humid places. Hereby batteries can be prevented from terminal oxidations and possible leakage currents.
- Please use aR or gR semi-conductor type fuse at the battery rooms and cabinets.
- If it is possible, please use breaker switch without fuse for the battery cabinet.
- Keep battery cabinets and shelves high above the ground. UPS should be protected against possible floods or liquid contacts.

- Battery rooms should be properly ventilated.
- Shelves will be accessible in touch if batteries are in battery room. Therefore, please keep restricted accessing to battery rooms. Use necessary safety writings and strips.

Especially, for the external cabinet batteries system of UPS, fuses must definitely be used. These fuses must be mounted as close as possible to the batteries. This closeness will increase the electrical operation safety with the battery.

Smart- BX UPS External Battery Cabinet Configuration			
Device Rating (kVA)	10	15	20
Batteries in series	31	31	31
Independent Group Number	2	2	2
Total number of Battery	62	62	62
I_charge_max@V_bat._max(A)	2,3	3,4	4,5
I_bat._max@V_bat._cut off(A)	13	19	26
Recommended external cabinet fuse (A)	20	32	40

External battery cabinet and battery room applications are given below as an example. The application form may vary according to the customer.

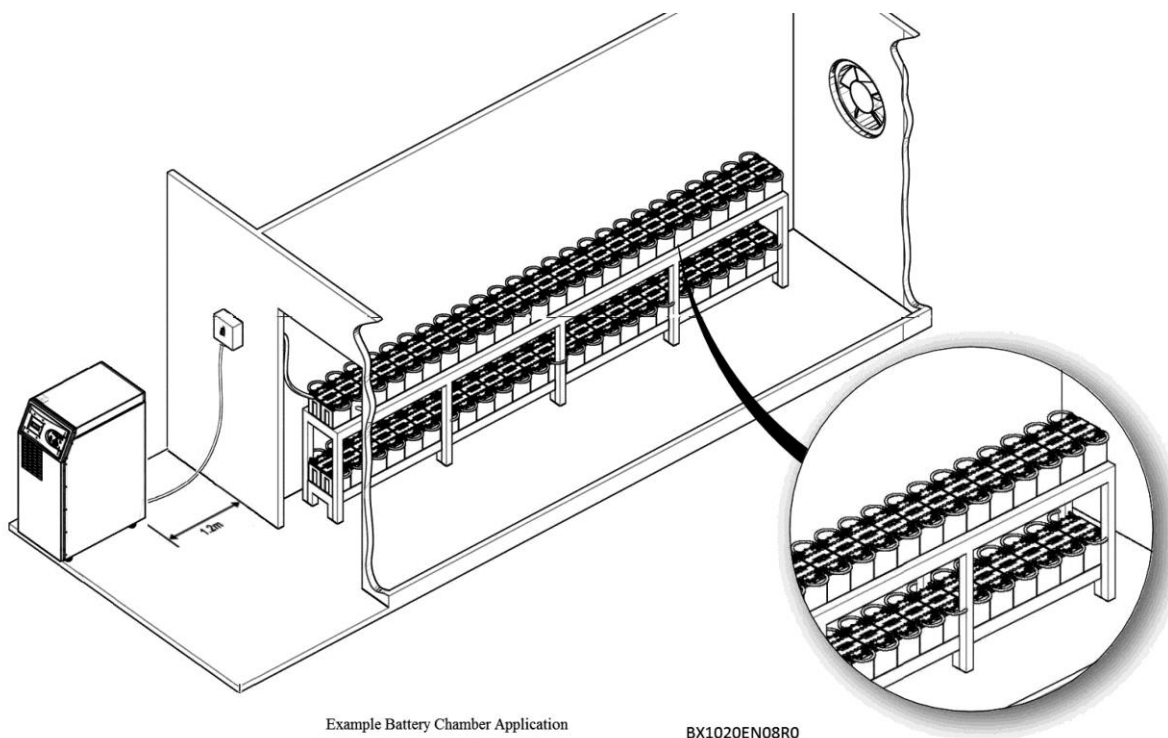

3.1.4 Transportation Type of Cabinets

Pay attention that carrying vehicles or handling accessories must have enough features and characteristics to carry the weight of the UPS.

UPS and optional battery cabinets are designed to be carried by a forklift or similar vehicles.

In addition, the UPS can be carried through its own wheels in short distances. Be more careful of sudden movements, especially when batteries are inside of cabinet. Move the UPS as rarely as possible.

3.1.5 Mains, Load and Battery Connections

Distribution board is recommended for the UPS outputs. Load protection fuses and breakers must be used in such distribution board. Additionally, fuses with various speeds may be needed according to load. A-B type fuses or magnetic breakers are recommended to be used if the load is suitable.

3.1.5.1 External Protections

To protect the AC inputs, thermal magnetic breakers or V-automat breakers must be independently installed on the distribution board. Herein, the cable intersections and fuse values must be determined and connected by an expert authorized person.

Over current protecting must be installed on mains input board. This protection must be selected in conformity with the bearing capacity of over current and over load of the UPS. The fuses in the board must be chosen as 135% higher rated than the current values given in the table below, and the fuses must be C-type (slow).

Ground leakages flow to the ground through the EMI filters on the input and the output of the UPS. Accordingly, **ENSMART POWER** recommends a residual current relay over 300mA.

The residual current relays to be placed in the UPS input must also be:

- ✓ Resistant to both positive and negative DC pulses,
- ✓ Not sensitive to transient currents.
- ✓ Must be sensitive to currents which is average between 0, 3-1 ampere.

3.1.5.2 Cable and Fuse Configuration

Cable designs must be compatible to current and voltage values stated herein, additionally local instructions must be obeyed about these topics.

UPS Rating (KVA)	Rated Currents (A)					
	Mains Currents at Maximum Battery Charge (3 phase + neutral)			Output Currents under Full Load (3 phase + neutral)		
	380V	400V	415V	380V	400V	415V
10	17,1	16,2	15,7	15,4	14,6	14,1
15	25,6	24,4	23,5	23,1	21,9	21,1
20	34,2	32,5	31,3	30,8	29,2	28,2

Non-linear loads (loads such as computer) may affect cable section design. Their neutral currents might be more than phase currents, even may rise up to 1.5 times the phase current.

Each cabinet must be, directly and as short as possible, to ground line by means of protection ground cable. Typical ground cable cross sections are 2,5 mm² for 10 kVA and 6 mm² for 15 kVA and 10 mm² for 20 kVA. It is recommended that cable length not exceed 5 meters.

3.1.5.3 Cable Connections

UPS input, output and battery connection inlets are made from the rear side of the UPS. Cable connections are performed after the big cover at the back of the device has been removed.



ATTENTION! 3 pole-circuit breakers (switch) are used for the input and output of the UPS, Neutral line is not interrupted.

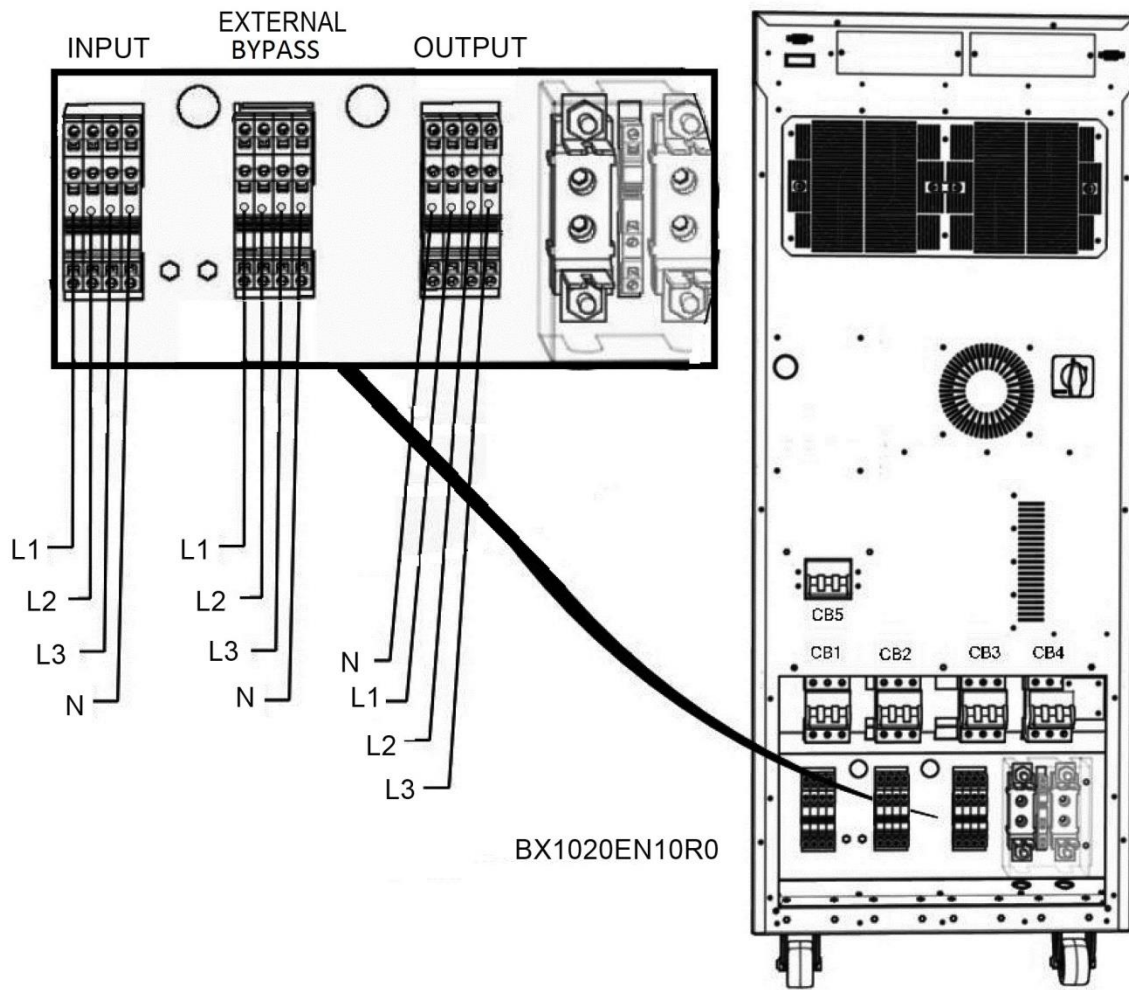

Please, follow the steps below for electrical connections:

1. Take all the breakers in the distribution boards open circuit (OFF) position and make sure that loads and the mains are isolated from cables

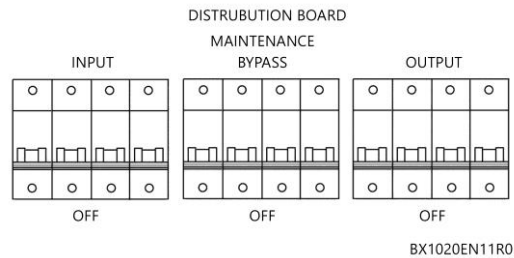

2. Remove the screws of the metal cover at the back of the UPS and take the board from its place.

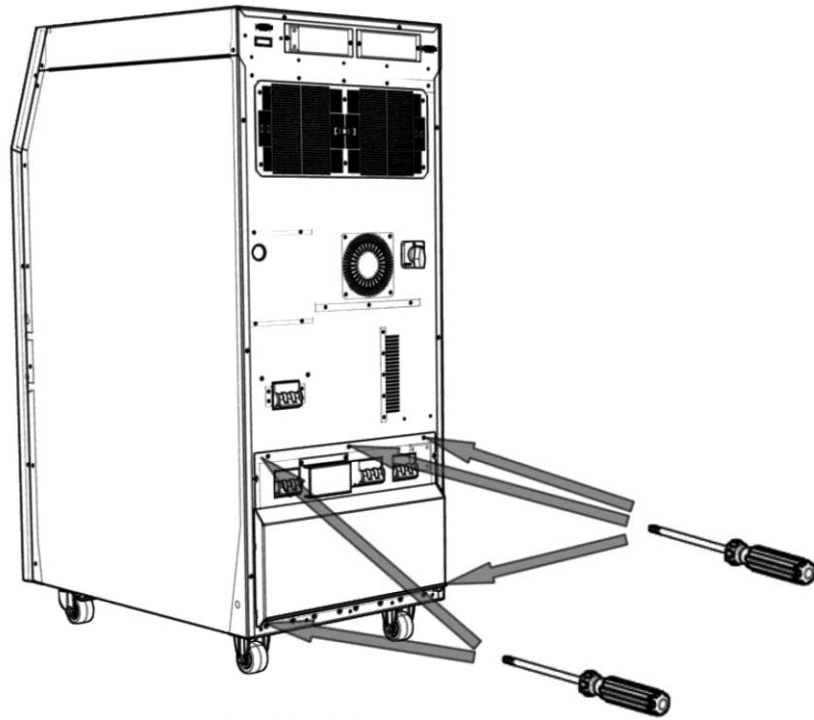

BX1020EN12R0

3. Connect the ground cable.

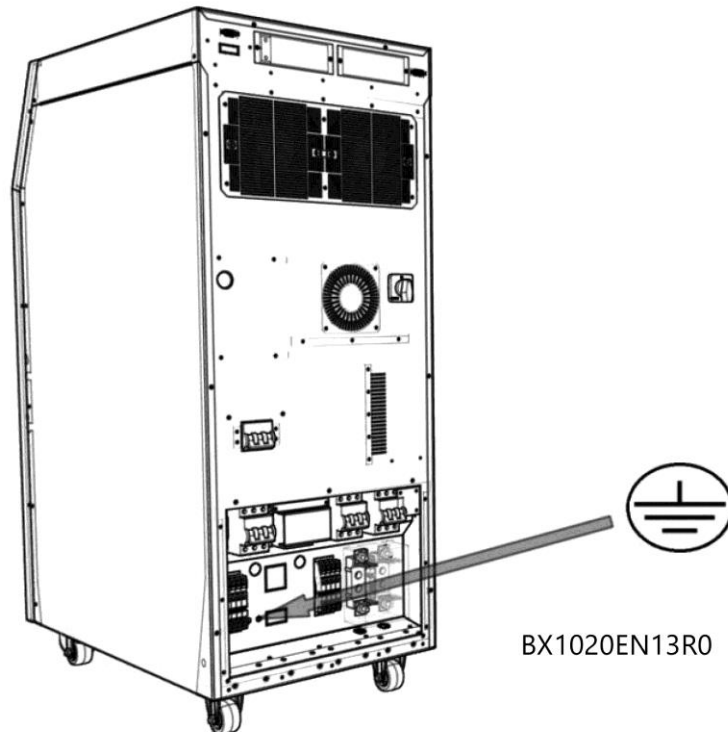

BX1020EN13R0

4. Make sure that all the circuit breakers are in the open circuit (OFF) position. The use of these circuit breakers are explained in the next sections

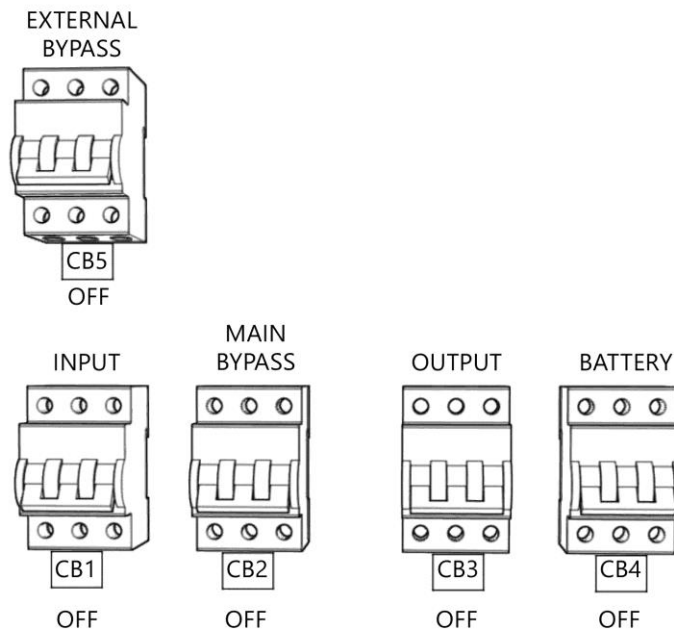

BX1020EN14R0

5. Connect the input cables:

- R phase to INPUT L1,
- S phase to INPUT L2,
- T phase to INPUT L3,
- N(Neutral) to Input N.

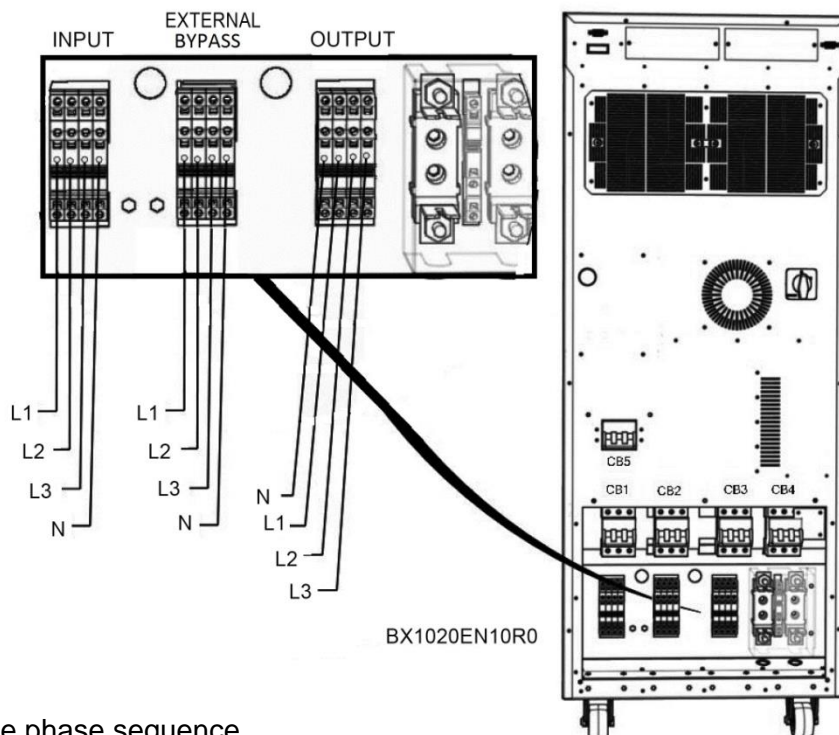

6. Check the phase sequence.

7. Repeat steps 4-5 for output cables.

8. Place the metal cover back and tighten its screws.

Use the cable clips to stabilize the cables when the connections are done.



Make sure that the loads in the output of the UPS prepared are isolated during the connection if they are not ready to be connected yet.



Before the UPS is started, make sure that cable connections have been made in accordance with the warnings in boards. Additionally, check if there is isolated transformer at the input of UPS and consider the local directions.



Make sure that grounding has been made properly. Wrong works or grounding made may damage the UPS and other systems in the installation.

3.1.5.4 Connecting Batteries

You can find details about internal and external batteries installation procedure and connections in this section.

3.1.5.4.1 Internal Battery Installation Procedure and Connection

Battery Installation Procedure

Follow the procedure below while commissioning internal batteries:

1. Remove battery fuse.
2. Make sure that serial and parallel connections of internal batteries are proper.
3. Connect the “- terminal” of the battery to the freed cable inside, named as “-BAT”, properly.
4. Connect the “+ terminal” of the battery to the freed cable inside, named as “+BAT”, properly.
5. Check battery connections once more and make sure that the poles are properly connected.



Avoid short circuiting batteries.
Exploding batteries can damage you and your environment!
Battery terminal may rise up to 450 Vdc!

6. Place the rear cover back and screw on completely.

Internal Battery Temperature Sensor

Information concerning temperature of internal batteries is read through NTC placed in the J26 socket of the main control board.

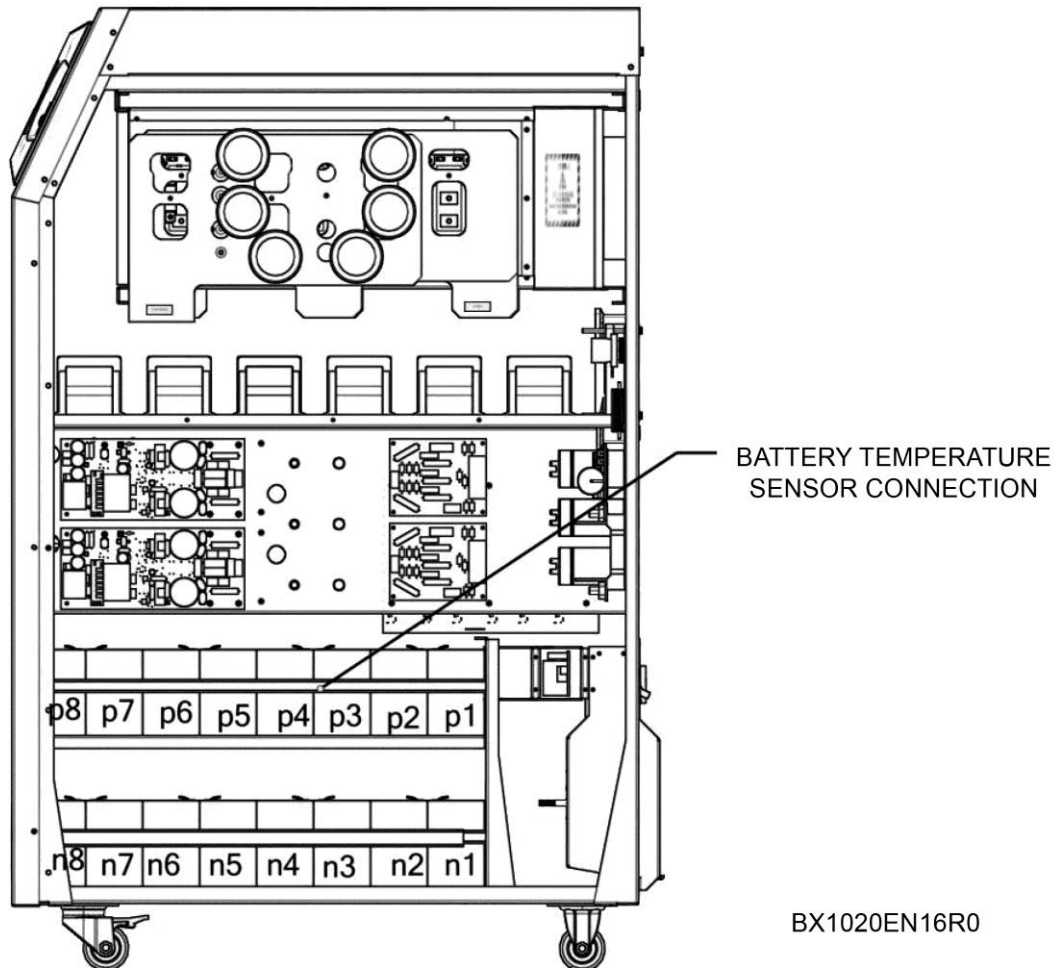

See the chapter of options for control of external batteries.

3.1.5.4.2 External Battery Installation Procedure and Connection

You can find details about how to configure the external batteries under “External Batteries Configuration” title above. The information about connection of external batteries and UPS is given in this section.



Avoid short circuiting batteries.
Exploding batteries can damage you and your environment!
Battery terminal may rise up to 450 Vdc!

1. Switch "CB4" breaker on the UPS to the position of open circuit (OFF).
2. If there is, switch breakers on the battery cabinet to the position of open circuit (OFF).
3. Remove the battery fuse on the battery cabinet.
4. Remove battery fuse on the UPS.
5. Make sure of serial and parallel connections of external battery packs are correct.
6. Connect the cable to terminals of two of the UPS, "N" (Battery Neutral)", one "+BAT" and one "- BAT" respectively.
7. Connect four cables that come from UPS to terminals on external battery cabinet or in battery room according to external battery connection diagram below. As follows:

➤ N(UPS)	←-----→	Positive Battery Group "-" terminal
➤ N(UPS)	←-----→	Negative Battery Group "+" terminal
➤ "+ BAT"	←-----→	Positive Battery Group "+" terminal
➤ "-BAT"	←-----→	Negative Battery Group "-" Terminal
8. Make sure that the polarities are connected correctly by checking battery connections for the last time.
9. Replace battery fuse on UPS.
10. Replace battery fuse on battery cabinet.
11. If there is, switch breakers on the battery cabinet to the position of closed circuit (ON).
12. Check if there is appropriate battery voltages to the battery input terminals of the UPS by means of a proper measuring device.

External battery cable selection is determined by application. Fuses which are recommended for the UPS and battery cabinet are given. To connect to these type fuses, the lowest diameter cables are suggested. Please, refer to the standard called EN 50525-2-31(VDE 0100-430) in this subject. The selection should be such that the cable will allow at most 0.5 Vdc decreasing.

There exists "**External Battery Temperature Measurement Kit**" to provide optimization of the batteries according to battery temperatures in the external battery cabinet application. Thus, battery charge temperature can be optimized according to the temperature. External battery connection scheme is given below:

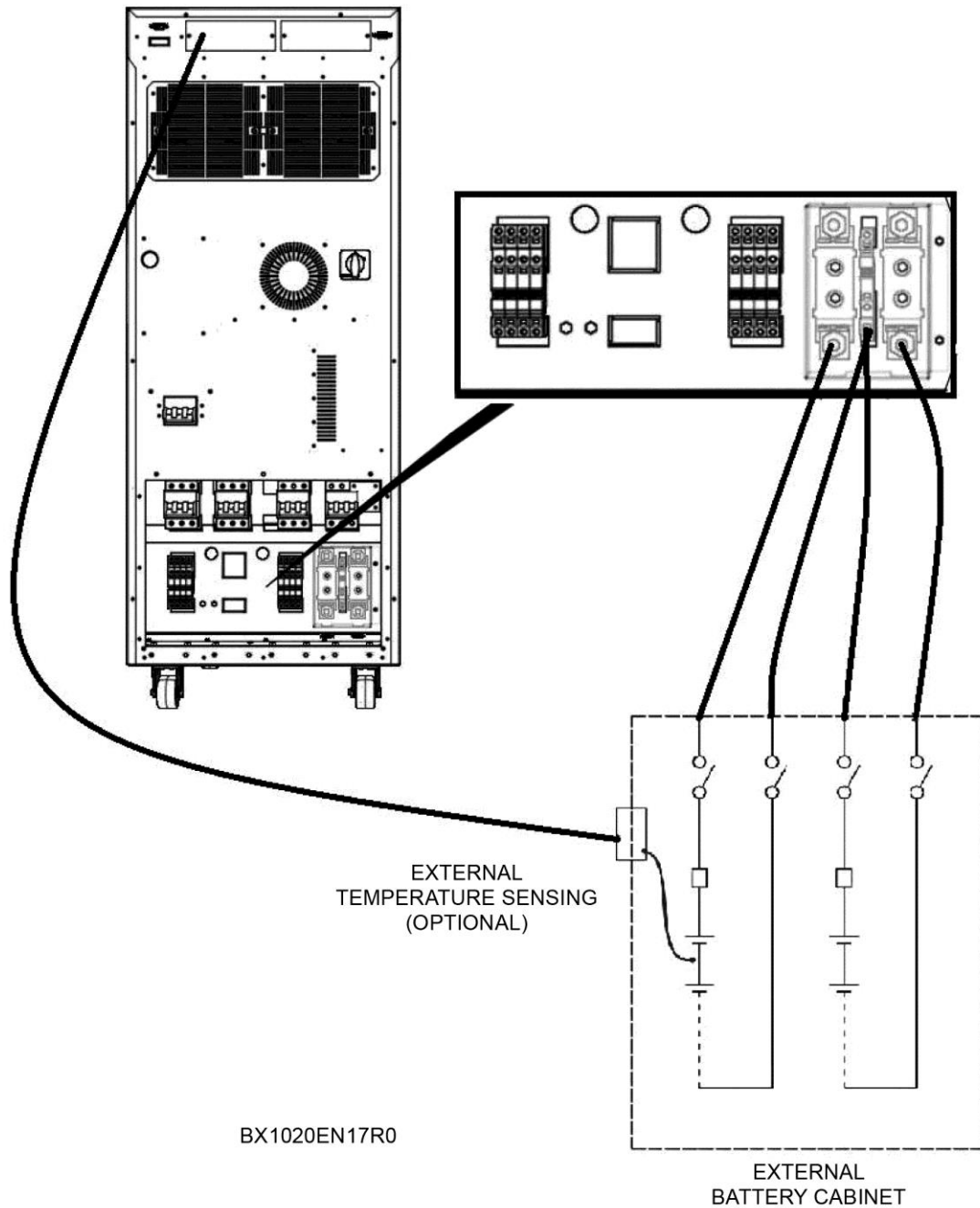

3.1.5.5 Control and Communication Cable Connections

EnSmart Power UPS products have standard or optional connections of advanced external battery cabinet, environmental monitoring, control panels and various intelligent monitoring.

Connections at the rear side of the UPS:

- One RS232 serial communication bus (Standard),
- Two expansion slots (Optional),
- One PARALLEL port (standard).

3.2 PARALLEL SETUP

The product which you have bought can be operated in parallel; however, this feature is offered as an option. Please contact your authorized dealer for parallel operation.



Parallel application should be made by authorized personnel assigned by EnSmart Power !

In case of need of redundancy or more power, Smart-BX UPS 10-20kVA devices can be operated as parallel up to the amount of 8. A principle scheme which shows a system in which two UPS are connected in parallel is given below:

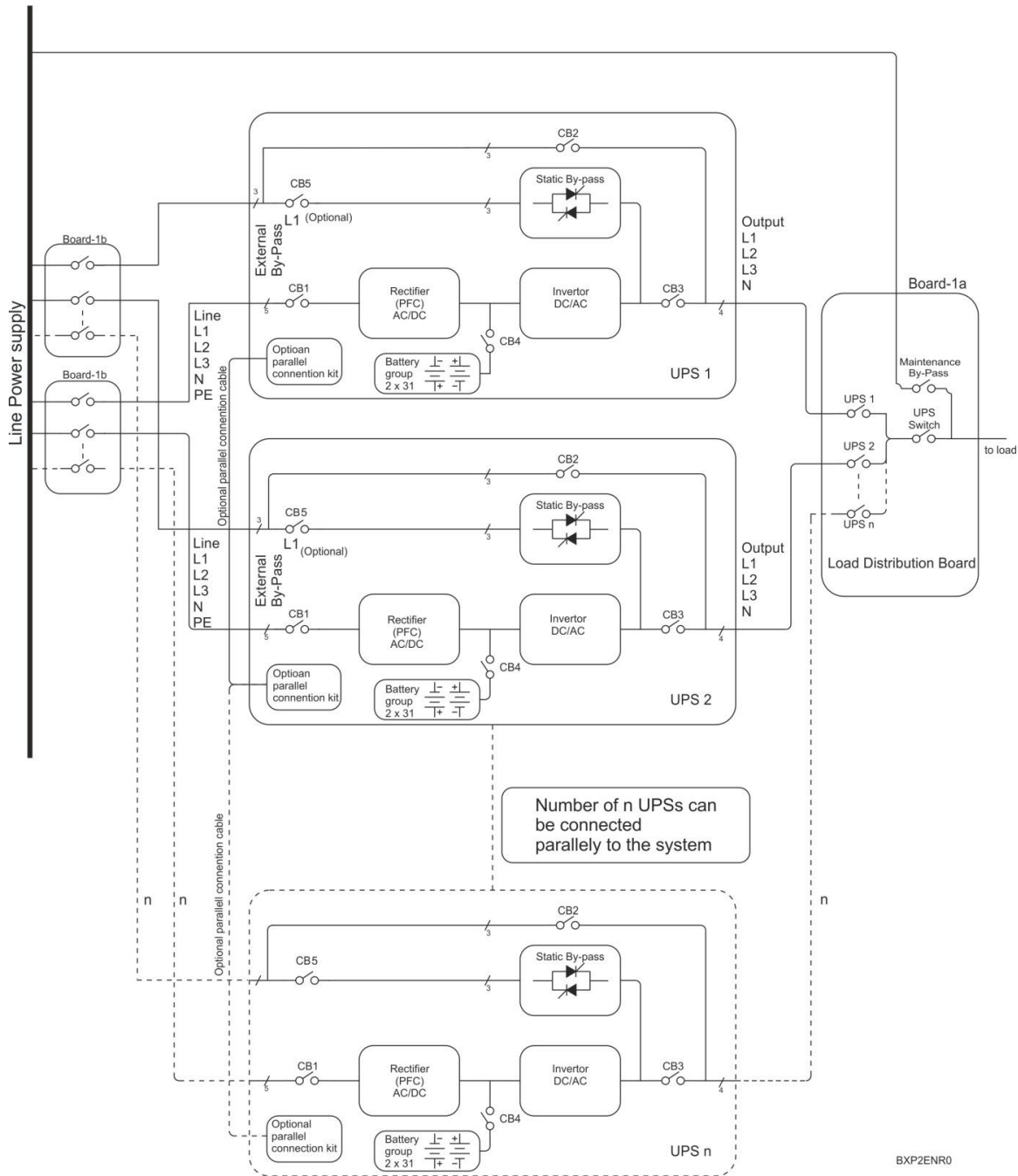

Input and output of more than one device are connected to each other; but definitely each battery group is different from another, batteries cannot be used in common. The following points should be considered while placement of devices in parallel system and their electrical connections are made:

- The devices which are connected in parallel must be from the same series and must have the same rated power.
- Devices must be running on the firmware with the same version and revision codes, devices operating with old firmware must be updated.

- Devices must be located as close possible as to each other (maximum 6 * 110 cm paralleling cables.)
- Each device must have its own neutral cable.
- Each device must have its own ground cable.
- Devices must be connected through the distribution board and phases must be properly connected. ($U_1-U_2-...-U_N$), ($V_1-V_2-...-V_N$), ($W_1-W_2-...-W_N$).
- Same battery group must not be connected to devices more than one
- For equal current sharing, all cables with which the devices are connected to the board must be equal in length and cross section.

Parallel Settings

Connect the parallel cable as shown in figure below. Only use the cables provided by **ENSMART POWER**.

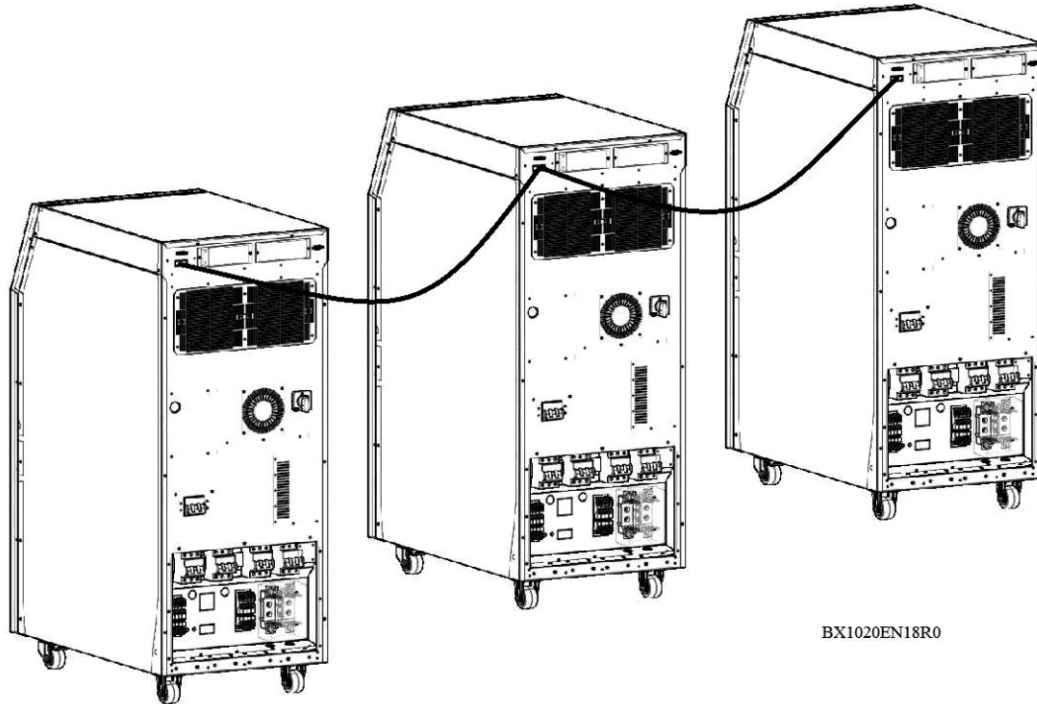

BX1020EN18R0

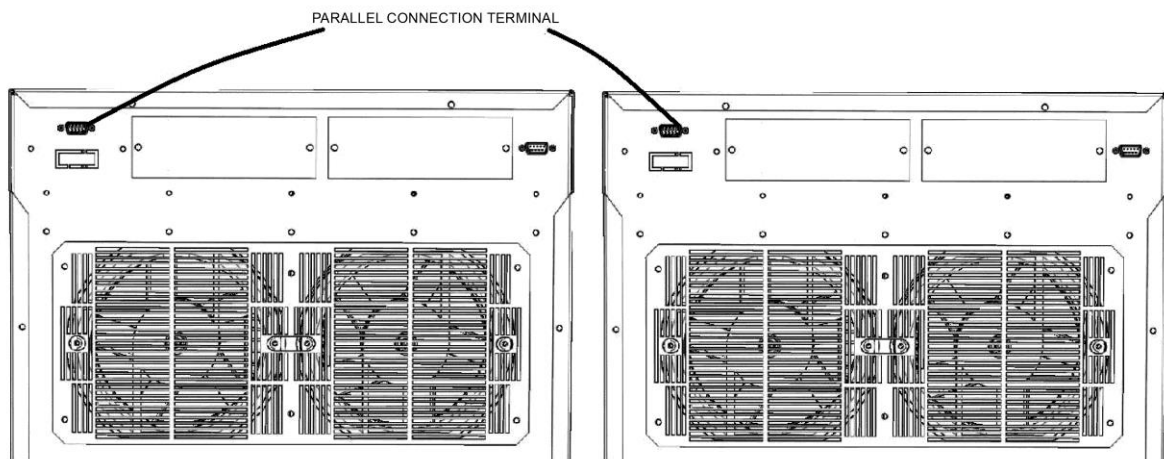

BX1020EN19R0

Software settings on the user panel should be made by authorized personnel.

4 OPERATION

4.1 OPERATION PROCEDURE

You can find information about circuit breaker, first start-up, types of UPS operation tests, turning UPS off, EPO and RS232 serial communication system in this section.

4.1.1 Circuit Breakers

The UPS has four circuit breakers accessible from the rear side. These are used for the AC input, maintenance Bypass, output and the battery connections respectively.

Three-phase AC voltage is applied through **CB1** to input of UPS.

AC input voltage will be applied directly to loads through **CB2**. In this way, maintenance purposed switching is done properly. Owing to the auxiliary contact detail in CB3, if it is activated while the UPS is operating, the mains activates Bypass static switches. The system switches to maintenance mode without any interruption.



CB3 is used to connect or separate AC voltage that come from static switches to the loads on UPS.

External batteries are connected to UPS through **CB4**.

Active Breakers	Operation Mode	Explanation
CB1, CB3, CB4, CB5*	Normal Mode	UPS operates in normal mode.
CB1, CB3, CB4, CB5*	Static Bypass Mode	UPS is overload, loads will be transferred to static bypass line temporarily.
CB2	Maintenance Mode	UPS is shut down for maintenance, maintenance is supplied through Bypass.

*CB5-External Bypass switch is optional.

4.1.2 First Start-Up



Wait at least 5 seconds between each step.

1. Switch all the breakers to open circuit (OFF) position.
2. Push the Soft Start button (SW1) for 10 seconds at least.

3. Switch the input breaker (CB1) to closed circuit (ON) position. If there exists optional external bypass, switch the external bypass breaker (CB5) to closed circuit (ON) position.

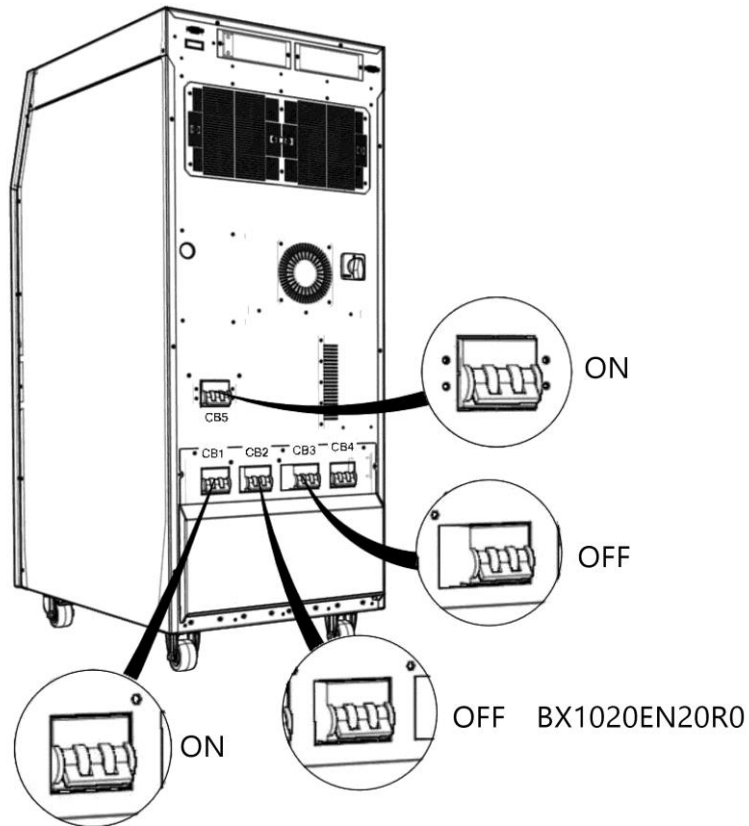

4. Start the UPS using the front panel.

Main Menu>Control>Password>Start

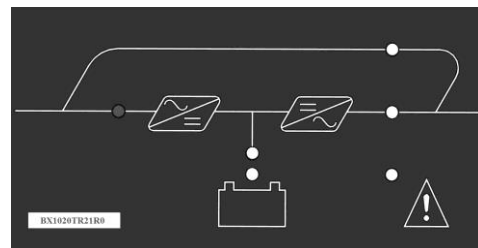

5. Check the device has switched to normal operation mode, via front panel display LEDs and LCD panel.

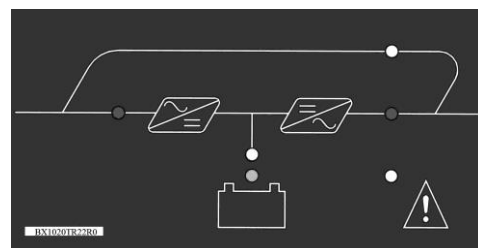

6. Switch battery circuit breaker (CB4) to closed circuit (ON) position.

7. Switch output circuit breaker (CB3) to closed circuit (ON) position.

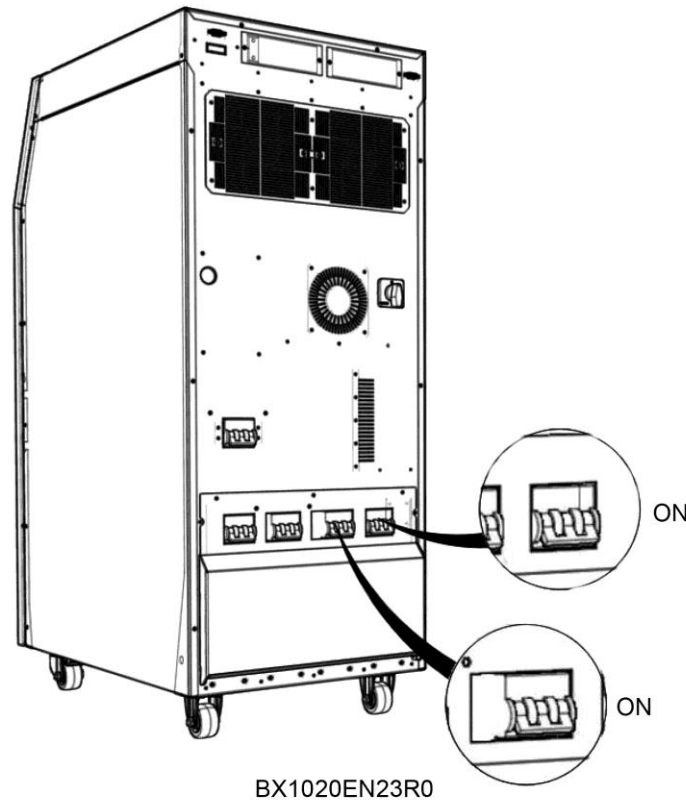

8. You can turn on the loads connected to the device.

After all these steps, check that load is fed through inverter static switches via mimic diagram. In a contrary situation, check UPS total and phase loads. The UPS gives audio alerts in an overload condition, without feeding critical AC loads.

4.1.3 Testing the Operation Modes of the UPS

After first start-up, switch among operation modes with the aim of control.

4.1.3.1 Switching from Normal Mode to Battery Mode

Take CB1 to open circuit (OFF) position. This action cuts off the mains voltage and the UPS starts operating on battery mode. After checking the operation, take CB1 to closed circuit (ON) position again.

4.1.3.2 Switching from Normal Mode to Static Bypass Mode

Switch the UPS to bypass mode via user panel. Check if static bypass led has flashed in mimic diagram.

Main Menu>Control> Switch to BYPASS

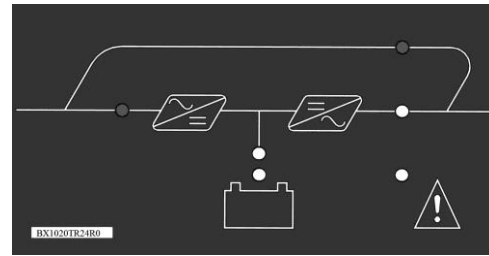

Note: The UPS will not switch to bypass mode if the mains is out of limits or phases are wrongly connected.

4.1.3.3 Switching from Static Bypass Mode to Normal Mode

Switch the device to UPS mode via user panel. Verify the case through mimic diagram.

Main Menu>Control> Switch to UPS

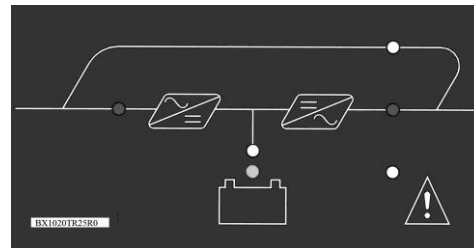

Note: The inverter will not undertake the load if the inverter voltage is out of limits or there is overload or over temperature situation.

4.1.3.4 Switching from Normal Mode to Maintenance Bypass Mode



Make sure that the inverter output is synchronized with the maintenance bypass line before switching to maintenance bypass mode. Otherwise, there is a possibility of cutting off the load power for a short while.



Switch the device to static Bypass mode using the front panel. Check If static bypass led has flashed in mimic diagram.

Main Menu>Control> Switch to BYPASS

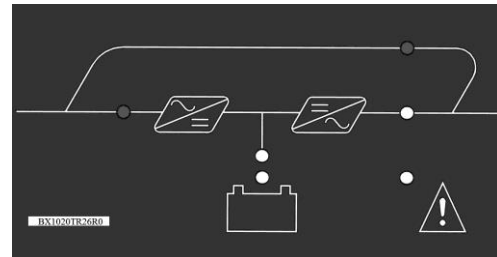

1. Take CB2 to closed circuit (ON) position.

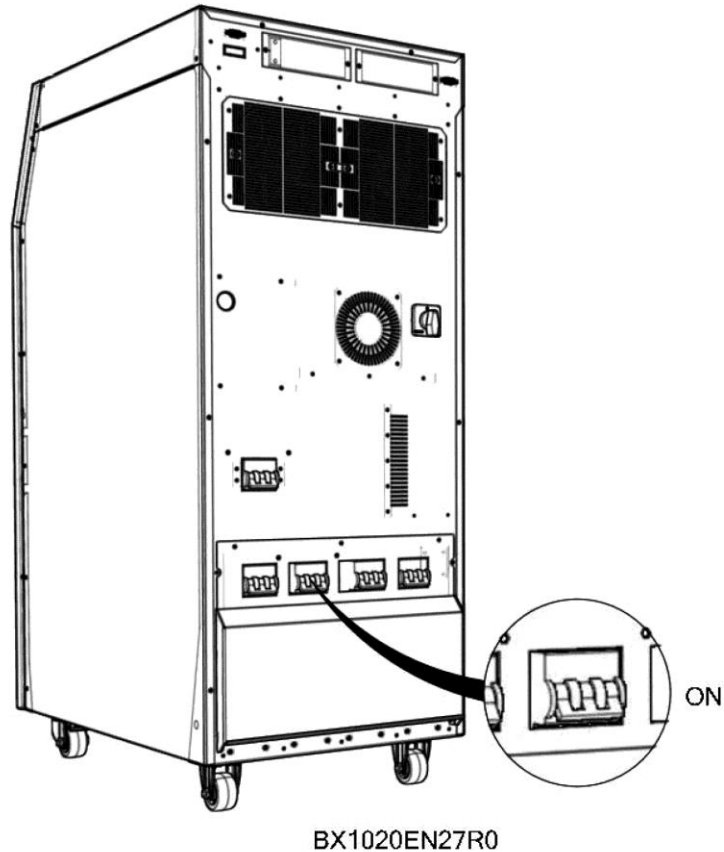

2. Stop the UPS using the front panel.

Main Menu>Control >Password>Stop



3. Switch CB1, CB3 and CB4 to open circuit (OFF) position.

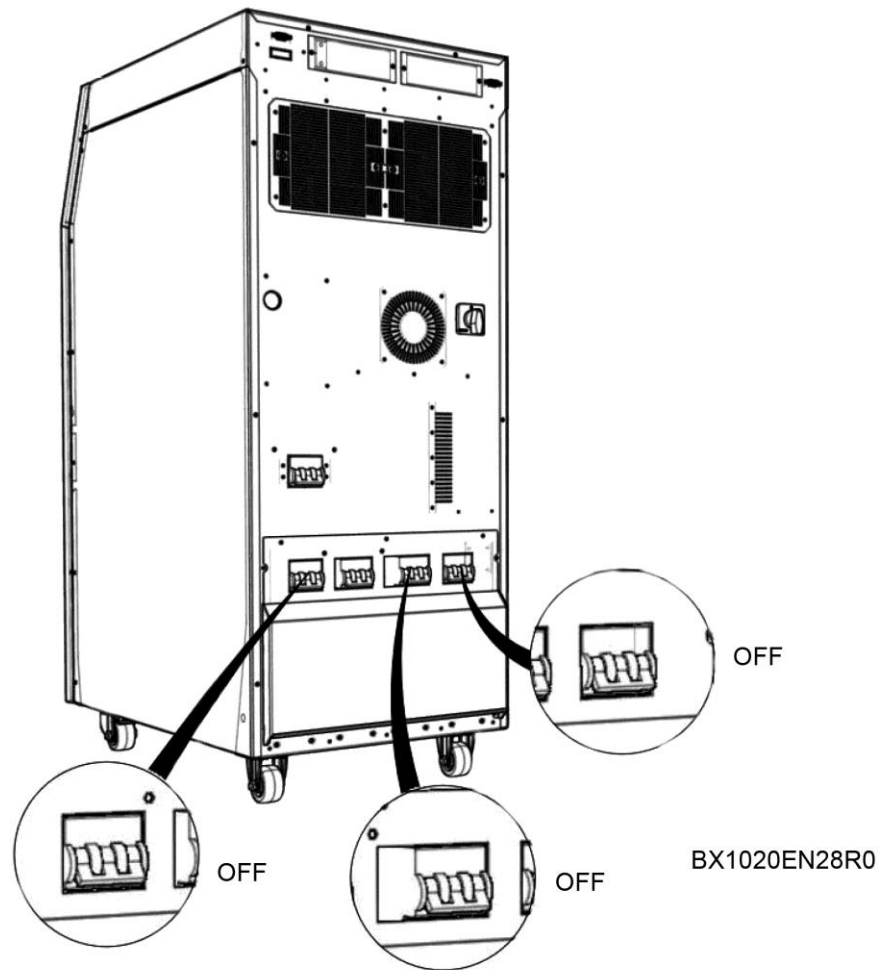

FOR SAFETY, WAIT 5 MINUTES AT LEAST BEFORE OPENING UP THE DEVICE AFTER YOU HAVE SWITCHED THE DEVICE TO THE MAINTENANCE BYPASS MODE.

4.1.4 Performing a Complete Shutdown

1. Turn off the loads connected to the device.
2. Stop the device using the front panel.

Main Menu>Control >Password>Stop



3. Check the UPS has switched to bypass mode, via mimic diagram LEDs and LCD panel.

4. Switch output (CB3), battery (CB4),input(CB1)and external battery (CB5) breakers to open circuit (OFF) position respectively.



MAKE SURE THAT THERE ARE NO CRITICAL LOADS ON THE UPS OUTPUT BEFORE PERFORMING A COMPLETE SHUTDOWN.

4.1.5 EPO (Emergency Power OFF)

By pressing the EPO button, the UPS turns the rectifier and the inverter off respectively. If the output breaker turn off option is set, the UPS completely disconnects from the system.

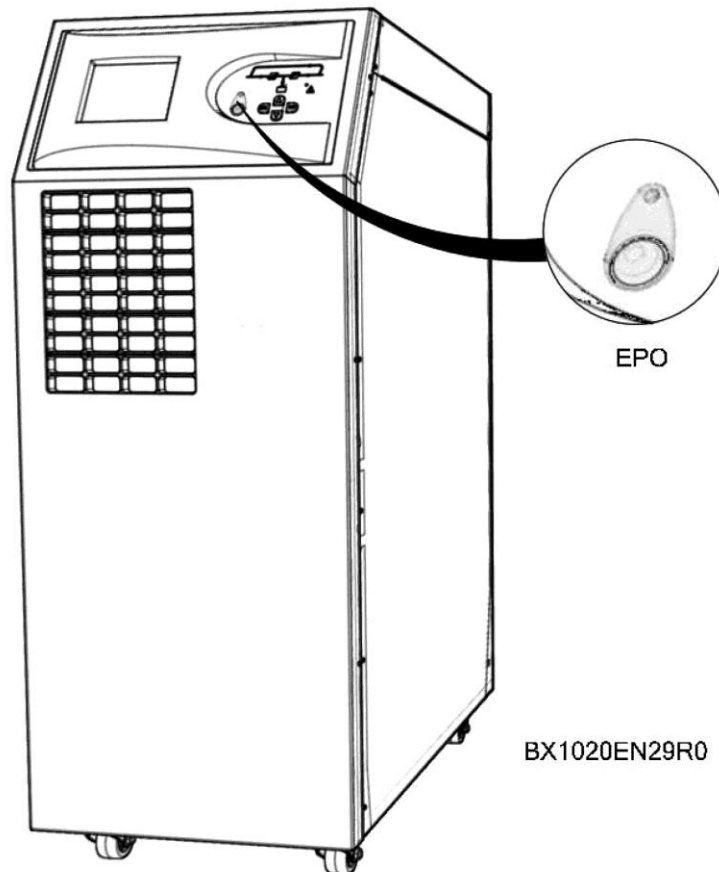

4.1.6 RS232 Serial Communication Installation and Examination

Smart-BX UPS 10-20kVA has an RS-232 interface which supports SEC and TELNET protocol as standard.

This interface is fully isolated and safe. The status of UPS can be monitored remotely via a PC or SNMP by using this protocol. This connection works with any kind of option.

5 EXPLANATIONS of LOGGING

The UPS will beep when any problem is detected. You can see the first information about the situation on the mimic status membrane. This may not be enough most of the time. In this case, you can see the following warnings by making use of log screen.

	Event	Explanations of Events
1	RS232 Start Command	UPS was started by RS232 communication software.
2	RS232 Stop Command	UPS was stopped by RS232 communication software.
3	Auto Restart	After the batteries discharge totally, UPS restarted itself automatically after the mean time which adjusted that follows the mains getting back to normal values.
4	UPS Startup	The main board of the UPS is energized.
5	Bus not Charged	UPS could not charge its bus to the desired value.
6	Quick Battery Test	Quick battery test has begun.
7	Deep Battery Test	Battery capacity test has begun.
8	Battery Self -Test	Periodical battery test has begun.
9	End Of Discharge	Batteries' voltage has gone below cut off voltage value while UPS was operating on the battery mode.
10	Overload Timeout	UPS has operated at overload more than time limit adjusted. The Loads will be transferred to bypass line.
11	End of Battery Test	Battery test has completed. Details concerning test results can be monitored via the battery status menu.
12	Battery Test Aborted	Test was aborted manually or by UPS since the criteria were not provided during battery test.
13	Manuel Switch To BYPASS	Static switches directions were changed manually to the bypass line via UPS command menu.
14	No Battery	UPS detected that no battery exists during operation.
15	Maintenance BYPASS Switch On	Maintenance bypass switch has been activated.
16	Abnormal Ambient Temperature	UPS operating ambient temperature exceeded the permitted limits.
17	Inverter Over Temperature	Inverter's temperature is out of limits, in the event of 5 degrees increment more, the load will be transferred to Bypass line.
18	PFC Over Temperature	Rectifier's temperature is out of limits, in the event of 5 degrees increment more, the load will be transferred to Bypass line.
19	STS Over Temperature	Static transfer switches' temperatures are out of limits. UPS will be stopped.
20	Output FL1 Over Current	Short circuit protection is activated for output L1 phase.

21	Output FL2 Over Current	Short circuit protection is activated for output L2 phase.
22	Output FL3 Over Current	Short circuit protection is activated for output L3 phase.
23	Bypass Voltage Bad	Bypass voltage value is out of limit while UPS was operating on the bypass mode. UPS will switch to normal mode if temperature and load status are normal, but if not, UPS will stop.
24	Bypass Frequency Bad	Bypass frequency value is out of limit while UPS was operating on the bypass mode. UPS will switch to normal mode if temperature and load status are normal, but if not, UPS will stop.
25	Coil Over Temperature	Over temperature is observed in UPS inverter or rectifier coils.
26	Inverter Voltage Bad	Inverter voltage limit values are exceeded. The load will be transferred to bypass line, when inverter voltage gets back to normal values, UPS will switch to normal mode again.
27	Overload	Output load value is over %105, overloading counter will start to count, If UPS is on normal mode, charging will be stopped until load value gets back to normal.
28	Maintenance BYPASS Switch Off	Maintenance bypass switch is deactivated.
29	Normal Ambient Temp.	UPS ambient temperature has got back to allowed limit values.
30	Normal Mains Voltage	Mains voltage is in the limited values, UPS will switch to normal mode.
31	Normal Inverter Temperature	Inverter temperature is in the limited values. If load and other temperature values are normal, UPS will switch to normal mode.
32	Normal PFC Temperature	Rectifier temperature is in the limited values. If load and other temperature values are normal, UPS will switch to normal mode.
33	Normal Charger Temperature	Charger/booster module temperature is in the allowed limits, charging will be activated again.
34	Normal STS Temperature	Temperature of static transfer switches is in the allowed limit.
35	Normal Bypass Voltage	Bypass voltage is within defined limits.
36	Normal Bypass Frequency	Bypass frequency is within defined limits.
37	Normal Coil Temperature	UPS inverter or rectifier coil temperature has got back to normal values.
38	Normal Inverter Voltage	Inverter voltage is in the limited values, UPS will switch to normal mode.
39	Normal Load	Output load is under %100, If charging was shut down, it will be activated.

40	BYPASSThyristorL1 Short Circuit	UPS has detected short circuit at bypass L1 thyristor. UPS will shut down.
41	BYPASS Thyristor L2 Short Circuit	UPS has detected short circuit at bypass L2 thyristor. UPS will shut down.
42	BYPASSThyristorL3 Short Circuit	UPS has detected short circuit at bypass L3 thyristor. UPS will shut down.
43	UPS ThyristorL1 Short Circuit	UPS has detected short circuit at inverter L1 thyristor. UPS will shut down.
44	UPS Thyristor L2 Short Circuit	UPS has detected short circuit at inverter L2 thyristor. UPS will shut down.
45	UPS Thyristor L3 Short Circuit	UPS has detected short circuit at inverter L3 thyristor. UPS will shut down.
46	UPS ThyristorL1 Open Circuit	UPS has detected that inverter L1 thyristor cannot be activated. Load will be transferred to bypass line.
47	UPS Thyristor L2 Open Circuit	UPS has detected that inverter L2 thyristor cannot be activated. Load will be transferred to bypass line.
48	UPS Thyristor L3 Open Circuit	UPS has detected that inverter L3 thyristor cannot be activated. Load will be transferred to bypass line.
49	BYPASS ThyristorL1 Open Circuit	UPS has detected that bypass L1 thyristor cannot be activated. Load will be transferred to inverter line.
50	BYPASS ThyristorL2Open Circuit	UPS has detected that bypass L2 thyristor cannot be activated. Load will be transferred to inverter line.
51	BYPASS ThyristorL3 Open Circuit	UPS has detected that bypass L3 thyristor cannot be activated. Load will be transferred to inverter line.
52	Parallel System Phase Sequence Error	One or more of UPSs which operate in parallel mode do not match in phase sequence.
53	Battery Start	UPS was given the command to start from the battery.
54	Parallel Start Error	One or more of UPSs which operate in parallel mode could not be prepared to operate.
55	Inverter Error	UPS couldn't prepare the inverter voltage when it was started.
56	Output Off	Static transfer switches all disabled. The loads cannot be energized.
57	Normal Mode	UPS is operating in the normal mode, loads are energized through rectifier – inverter line.
58	Battery Mode	UPS is operating in the battery mode, loads are energized through battery – inverter line.
59	Bypass Mode	UPS is operating in the bypass mode, loads are energized through bypass line.
60	Maintenance Bypass Mode	UPS is operating in the maintenance bypass mode, loads are energized through maintenance bypass line.

61	Parallel Mode	2 or more UPS are operating in power sharing mode. Load is fed through UPSs' inverter lines.
62	Test Mode	UPS has switched to battery test mode, loads are energized through rectifier- battery- inverter line as source sharing.
63	Switch to Inverter Mode	Switching to inverter mode command has been given via front panel.
64	Output Voltage Error	Output voltage is detected during the period of starting UPS. UPS has been stopped.
65	PFC Stop Command	Abnormal situation is detected during the moment of rectifier operating. UPS has given a command to stop itself.
66	Start Command	Start command is given via UPS command menu.
67	Stop Command	Stop command is given via UPS command menu.
68	UPS Stopped	UPS has been stopped.
69	Bypass Error	UPS has switched to bypass mode so many times in a short period, UPS will be shut down.
70	Parameters Changed	Device-related parameters were changed on the service menu.
71	Battery Changed	Battery replacement date has been changed. Battery statistics will be reset.
72	Load Impact Transfer	The load which cannot be handled by inverter is activated. Loads will be transferred to bypass line.
73	Parallel Command	An UPS which is operating in parallel mode has been given a command to change the status of static switches.
74	No Parallel CAN Bus Communication	Slave UPS which is operating in parallel mode can't reach to master UPS from CAN bus. If UPS is operating, will be shut down.
75	Externally Start Command	UPS which is operating in parallel mode has been received a command to start up by another UPS.
76	Externally Stop Command	UPS which is operating in parallel mode has been received a command to stop by another UPS.
77	Externally Switch To BYPASS.	UPS which is operating in parallel mode has been received a command to transfer the load to bypass line.
78	Externally Switch To UPS	UPS which is operating in parallel mode has been received a command to transfer the load to inverter.
79	Parallel Communication FE Error	Slave UPS which is operating in parallel mode has detected a failure of input current sharing.
80	Inverter OKEY	Inverter voltage reached needed value after UPS is started up. UPS can feed the loads through inverter.
81	Abnormal Battery Temperature	Battery temperature is out of defined limits, batteries can be damaged.
82	EPO key pressed	EPO button is pressed.
83	Low Battery	Battery capacity has decreased below defined battery low limit while UPS was operating in battery mode.

84	No Parallel 485 Communication	No RS485 communication between the parallel systems is available.
85	STS Over Current	Time of over load in Bypass line is up.
86	BYPASS Phase Sequence Error	Reverse phase sequence was detected in mains at the UPS run time.
87	Output DC Voltage Error	Inverter DC voltage limit has been exceeded. Loads will be transferred to the bypass line.
88	Output Offset Error	One or more phases of slave devices' output is not connected to master device in parallel systems.
89	Normal Battery Temperature	Battery temperature is within limits.
90	PFC Pbus Over Voltage	Positive bus voltage limit excess.
91	PFC Nbus Over Voltage	Negative bus voltage limit excess.
92	PFC FL1 Over Current	Short circuit protection is activated in rectifier L1 phase.
93	PFC FL2 Over Current	Short circuit protection is activated in rectifier L2 phase.
94	PFC FL3 Over Current	Short circuit protection is activated in rectifier L3 phase.
95	Single Stop	Command to stop itself has been given to UPS which is operating in parallel mode separately from parallel system.
96	Master Changed	UPS became master device in parallel system.
97	Parallel ID Coincidence	ID values of one or more device are the same as each other in parallel system.
98	Stop All	Stop the whole parallel unit command was given via front panel.
99	Power Supply Error	An error signal is detected through power source circuit debugger.
100	Generator Mode	Signal is detected from generator mode input of dry contact board. UPS will switch to generator mode.

6 TECHNICAL SPECIFICATIONS TABLE

Technical Specifications			
Power	10kVA	15kVA	20kVA
Active Power	8Kw	12kW	16kW
INPUT			
Input Voltage Range	220/380 VAC - %15 + %18 3P + N + PE		
Input Power Factor	At Full Load > 0,99		
Input Frequency Range	45-65 Hz (Selectable)		
Rectifier	IGBT Rectifier		
Total Harmonic Distortion (THDi)	<4%		
OUTPUT			
Output Voltage	220/380 VAC 3P + N \pm 1% Static, \pm 1% Dynamic		
Recovery	At 0% - 100% - 0% load maximum output tolerance 5%, 1% back to band<40ms.		
Efficiency	Up to 93%.		
Output Frequency Range	In 50Hz \pm 0,5% range synchronous with the network, 50Hz \pm 0,2% battery mode		
Output Harmonic Distortion (THDv)	Linear Load<2%		
	Non-Linear Load <6%		
Crest Factor (CF)	3:1		
Overload Capacity	At 125 % load 10 minutes, at 150 % load 1 minute.		
Protections	The input voltage is out of tolerance, input frequency is out of tolerance, input phase failure, output voltage is out of tolerance, output frequency is out of tolerance, output phase failure, DC component that can occur at the output voltage, Overload that will occur at the output (out of the periods specified), Overheating that will cause failure related to over temperature, high voltage which will occur at DC bus voltage, low voltage which will occur at DC bus voltage, short circuit at the output.		
BATTERY			
Quantity (12V DC VRLA)	62 (consists of 2 independent 31 battery groups)		
Charge Value (C)	Nominal 0.1 C, selectable.		
Battery Power	25% of the device power		
COMMUNICATION			

Communication Port	RS232 Standard, RS485 and SNMP Adapter option		
Dry Contact	Optional		
Protocol	SEC, TELNET		
CERTIFICATES			
Quality	ISO 9001		
LVD/ Safety	IEC 62040-1, IEC 60950		
EMC	IEC 62040-2		
GENERAL			
Running Temperature	0 °C ~40 °C range (for batteries 0 ~ 25 °C)		
Storage Temperature	-15 °C ~ 45 °C range (for batteries -10 ~ 60°C)		
Protection Class	IP20		
Chassis	Anti-Static Paint Protection		
Humidity	0-95 %		
Operating Altitude	<1000m, Correction Factor 1. <2000m, Correction Factor >0,92, <3000m; Correction Factor >0,84		
Logging	500 detailed event log. (Status Menu is recorded)		
Parallel Operation	Parallel power increase up to 8 pieces		
EPO (Emergency Power Off)	Standard		
Isolation Transformer	Optional		
Net Weight (Without Battery)	100 kg	100 kg	110 kg
Dimensions (W x D x H)mm	460x805x1190mm		

7 CONTACT INFORMATION



www.ensmartpower.com