



www.ensmartpower.com

UNITED KINGDOM

Kemp House 160 City Road, London, EC1V 2NX,
United Kingdom
T: +44 20 3808 85 60
E: sales@ensmartpower.com

TURKEY

Halk Cad. No:8/A3, Atasehir
Istanbul –Turkey 34752
T: +90 216 225 84 66
E: sales@ensmartpower.com

Follow us on

[/ensmartpower](#) [/ensmart_power](#) [/ensmartpower](#) [/ensmartpower](#)

www.ensmartpower.com



SMART TP UPS

Models 10-120kVA

H Version For External Battery

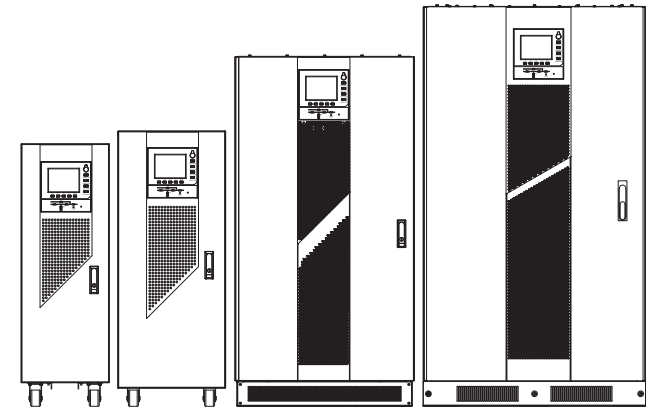

User Manual

FOREWORD

Thank you for choosing this product of **SMART-TP UPS 10kVA - 120kVA** range.

EnSmart Power is highly specialised in the development and production of uninterruptible power supplies (UPS). The UPS device described in this manual is designed and manufactured with care to guarantee uninterrupted power for your equipments and give you the best performance. The UPS are only designed for commercial/industrial purposes. It is not used to power life-support equipment of any kind.

This manual contains detailed instructions for product use and installation/operation of the stand-alone and parallel UPS systems. **The SMART-TP UPS can be only used only by authorized engineers appointed by manufacturer or its agents.** For information on using and getting the best performance from your UPS, this manual must be stored in a safe place and **CONSULTED BEFORE TAKING ANY ACTION ON THE UPS.**

Due to the constant update and improvement of the product and the technology, contents in this manual may not be consistent with the actual conditions of the product. We appreciate your understanding for that. **Please contact the manufacturer or the supplier for the latest information if necessary.**

Note: Because of the continuous improvements, our products may differ somewhat from the contents included in this manual. You can contact local office to get the information when necessary.

Contents

1. Introduction	7
1.1 Features	7
1.2 Design Concept.....	8
1.2.1 System Design	8
1.2.2 Bypass Circuit	8
1.2.3 System Control Principle.....	9
1.2.4 ECO Mode (only suitable for the UPS standalone machines)	11
1.2.5 UPS Power Switch Setting	11
1.2.6 System Capacity Expansion	11
1.3 Operation Mode.....	11
2. Mechanical Installation.....	14
2.1 The Do's and Don'ts	13
2.2 Environment Requirements	13
2.21 Site Selection for the UPS	13
2.22 Site Selection for the Battery	14
2.3 Mechanical Requirements	14
2.31 System Configuration.....	14
2.32 Moving the Cabinets	14
2.33 Operation Space	14
2.34 Wiring	14
2.4 Initial Check	15
2.5 Installation Diagram	15
3. Electrical Installation	20
3.1 Wiring of Power Cables	20
3.11 System Configuration.....	20
3.12 Cable Specification	20
3.13 The Do's and Don'ts.....	21
3.14 Cable Connector	21
3.15 Protected Area	21
3.16 Protector.....	22
3.17 Connection Procedure for the Power Line.....	22
3.3 Wiring of Control Cables.....	22
3.31 Monitor Board Port.....	22
4. Display Panel of Operation Control	33
4.1 Introduction.....	33
4.11 LED Indicator.....	33

4.12 Alarm Buzzer.....	34
4.13 Control Buttons	34
4.14 LCD and Menu Button	35
4.15 Detailed Menu	36
4.16 EPO Button	40
4.2 Prompt Windows.....	40
4.3 UPS Alarm Message List.....	40
5. UPS Operation Instruction	45
5.1 Introduction	45
5.11 The Do's and Don'ts	45
5.2 UPS Start-up Procedure (Entering the Inverter Power Supply Mode).....	45
5.3 UPS Start Procedure (Entering the Economic Mode).....	40
5.4 Battery Test Procedure	40
5.5 UPS Self-detection Procedure	41
5.6 Maintenance Bypass Operation Procedure (UPS Shutdown Procedure).....	41
5.7 Shut-down Procedure (Complete Shut-down of the UPS and Loads).....	42
5.8 Emergency Shutdown (EPO) Procedure.....	42
5.9 UPS Reset Procedure	43
5.10 Automatic Start.....	43
5.11 Language Selection	43
5.12 Alteration of the Current Date and Time.....	50
6. Battery	51
6.1 Introduction	51
6.2 Safety	51
6.3 UPS Battery	52
6.4 Installation and Design Notice.....	52
6.5 Installation Environment and Number of Batteries to be Installed	53
6.5.1 Installation Environment.....	53
6.5.2 Number of Batteries	53
6.6 Connecting the Battery	54
6.6.1 Battery Assembling	54
6.6.2 Battery Wiring.....	54
6.7 Battery Installation	54
6.8 Battery Maintenance.....	54
6.9 Battery Recycle.....	55
7. Parallel System.....	50
7.1 Introduction	50
7.2 Installation of the "1+N" Parallel System	50

7.2.1 Initial Check.....	50
7.2.2 Cabinet Installation	50
7.2.3 Protector.....	51
7.2.4 Power Cables.....	51
7.2.5 Control Cables	51
7.3 Operation Procedure for “1+N” Parallel System	60
7.3.1 Start-Up Procedure (Entering the Inverter Power Supply Mode)	58
7.3.2 Operation Procedure for the Maintenance Bypass (UPS shut down).....	59
7.3.3 Shut Down and Isolate One of the UPS Machines in the Parallel System	59
7.3.4 Resume the Isolated Stand-alone Machine in the Parallel System.....	59
7.3.5 Shut-down Procedure (Complete Shut-down of the UPS and Loads)	60
7.4 Dual Bus System (Optional)	60
7.4.1 Cabinet Installation	60
7.4.2 Protector.....	60
7.4.3 Power Cable.....	60
7.4.4 Control Wire	60
8. Product Specification	63
8.1 Compliance and Standards	63
8.2 Environment Condition	63
8.3 Mechanical Characteristics.....	63
8.4 UPS Electrical Characteristics (Rectifier Input).....	64
8.5 UPS Electrical Characteristics (DC BUS)	64
8.6 UPS Electrical Characteristics (Inverter Output)	59
8.7 UPS Electrical Characteristics (Bypass Input)	60
9. Maintenance and Repair	61
9.1 Safety.....	61
9.2 UPS Key Components and the Service Life	61
9.2.1 Magnetic: Transformer and Inductor.....	61
9.2.2 Power Semiconductor	61
9.2.3 Electrolytic Capacitor	61
9.2.4 AC Capacitor	61
9.2.5 Service Life for the UPS Key Components.....	62
9.2.6 Change Fuse.....	62

Safety



Compliance and Standards

This equipment meets the following UPS reference standards:

- IEC60950-1 and IEC62040-1-1 safety requirements for operating area
- IEC/EN62040-2 EMC requirements
- IEC62040-3 performance requirements and test method

The installation must comply with the above requirements and use the required attachment by the manufacturer.



WARNING

Earth leakage current: Before connecting with the input power, please ensure a safe and reliable grounding.

The grounding must comply with the local electrical code.

The protection device for the power-connected end of the UPS system must comply with the local electrical code.

In case the internal fuse of the UPS breaks down, it should be replaced with a fuse of the same electrical specifications and the replacement should be done by professional staff.



Watch Out

This equipment contains a RFI (radio frequency interference) filter.

The earth leakage current ranges between 3.5mA and 1,000mA.

When selecting RCCBs (residual current circuit breaker) or other RCDs (Residual current Device), you should take into account the transient state and steady state of the leakage current upon starting the equipment.

The selected RCCB should not be sensitive to one-way DC pulse (A) and transient current pulse.

Attention: The earth leakage current of the loads will also flow through RCCB or RCD.



General Safety

Like other high-power equipment, UPS and its battery box have high voltage. Yet as the high-voltage components will only be exposed to the outside when the front door (with a lock) is opened, thus the possibility of exposure to high voltage is reduced to the minimum. In accordance with the IP20 standards, the equipment includes other internal safety shields.

No danger will be involved if you follow the general standards and the procedure suggested in this manual.

As all the maintenance and repair of the equipment involves the internal components, it should be done by professional staff.



Battery

The battery manufacturer offers the do's and don'ts for using large-scale battery and staying around such place, which should be strictly followed at all times. Particular attention should be paid to suggestions about local conditions and regulations on the protective work suits, first-aid equipment and fire fighting apparatus.



Dangerous Voltage

When doing the maintenance, pay attention that the N wire has electricity.



Multiple Power Input

The UPS has multiple powers. All the AC powers and DC powers should be cut off before maintenance and repair.



Attention

The output neutral line is connected to the input neutral line. It would cause danger if external device disconnect the neutral line, which results in the miss of the output neutral line.

The standard UPS system can be connected to the three-phase four-wire (earth connected) TN and TT AC power distribution system (IEC60364-3) . If used in IT AC power distribution system, the input end requires a four-pole breaker, which may follow the related IT system standard.

Pay attention to electric shock. Even when the AC input power is cut off, there is still high voltage of electric conduction components supplied by battery inside the equipment.

The UPS is equipped with large-volume capacitors. When the equipment is cut off from electric supply and battery, the voltage at the terminal of the capacitors remain for some time. Before the maintenance and repair of the equipment's internal part, wait for at least 5 minutes after the UPS is shut down, and measure the voltage between the bare metal parts to make sure that the voltage is below the safety threshold. Failure to observe the instruction may lead to serious electric shock and even death.

This warning sign stands for all kinds of safety warnings.



1. Introduction

This chapter briefly introduces the features, design concept and operation model of the UPS.

1.1 Features

The UPS is connected between the three-phase input power and important loads (like computer) and offers quality three-phase power to the loads. It has the following features:

- Full digitalized technology

Dual-DSP control chip, advanced control technology, enhanced logic management and eliminated zero drift with analog control; convenient use of modern control technology; convenient debugging, system update and maintenance; perfect logic functions; diverse interactive data for the customers; convenient communication and network functions

- Highly reliable topological structure

The rectifier adopts the most reliable thyristor phase-control technology; the inverter adopts IGBT module half-wave structure and the inverter transformer helps isolate the input and output electricity, which increases safety and shock resistance of the system; the battery is directly connected to the bus bar, and the transfer time from AC-inverter Mode to Battery Mode and vice versa is zero, which increases the reliability of the system; the switching between inversion and bypass is controlled by a static transfer switch, and the switching time is as short as 0ms.

- Outstanding input and output features

The POWER WALK IN helps achieve gradual connection to oil engine so as to prevent unreliable start of the engine in the parallel operation system; applicable in several voltage systems, i.e. 380V/400V/415V; 50HZ, 60HZ; meets most of the voltage systems in the world; high output power factor (0.9 lagging) which strengthens the system's load capacity and ensures sufficient overload capacity.

Generator mode: Set the maximum output power of the generator when a smaller one than needed is employed to extend the battery duration time. In this case, the load is supplied by both the generator and battery.

- Smart Battery Management

The automatic switch between equalizing charge and floating charge, prediction for the discharge time, and regular self-examination increase the service life of the battery.

- N+X parallel operation mode

It is convenient to achieve parallel operation. You only need to connect the parallel cables and set the UPS, and the host is automatically produced. In case the host breaks down, the slave automatically becomes the host, which increases the reliability of the system. The system can have at most 6 sets of UPS connected in parallel.

- LBS synchronization

LBS synchronization allows the system synchronization of two sets of UPS. It is suitable for STS (Static Transfer Switch) Dual Bus configuration, in which the STS input, connected to the output of the two independent UPS and the output to the load.

- Perfect protection

Over-voltage protection; over-frequency protection; over-current protection; over-voltage protection for bus bar; over-temperature protection; fault protection for auxiliary power supply; output overload protection; output short-circuit protection; emergency power-off.

- Perfect monitoring

Support RS232 and RS485, large LCD screen display; monitoring parts help monitor the working condition of UPS, give instructions, record fault time and other local monitoring functions, and also help achieve the communication between UPS lower machine and monitoring upper computer, and control the auxiliary system.

1.2 Design Concept

1.2.1 System Design

This section introduces the operating principle of the stand-alone UPS. The UPS adopts AC-DC-AC converter (see Figure 1-1). The first AC-DC conversion adopts three-phase full bridge controlled rectifier to convert the three-phase AC input power into the steady DC bus voltage.

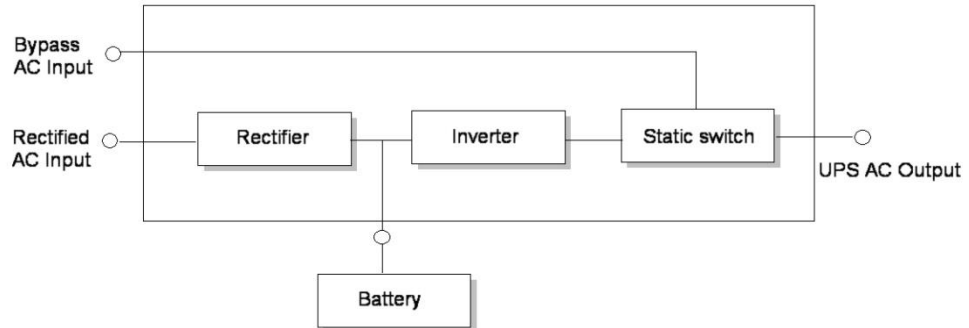

Figure 1-1 Working Principle of the Stand-alone UPS

The rectifier can also be used as a charger. The inverter takes IGBT half-wave circuit as its inversion topology. The advanced Space Vector Pulse Width Modulation (SVPWM) is used to control the system, which inverts the DC bus voltage into AC voltage output.

When the AC is normal, the rectifier and the inverter work at the same time and simultaneously charge the battery. In case of abnormal AC, the rectifier stops working and the battery supplies power via the inverter. If the battery voltage drops below the cutoff voltage and the AC is not yet back to normal, the UPS shuts down (If the major circuit and the bypass circuit are not of the same source and the bypass circuit is normal, the system is powered by the bypass circuit). The cutoff voltage is preset (eg. the factory setting is 1.67V and the battery cutoff voltage is 320Vdc).

In case of abnormal AC, the battery powers the UPS until its voltage drops to the cutoff voltage. This period of time is called the “backup time”, the length of which depends on the battery’s capacity and the loads.

1.2.2 Bypass Circuit

1. With the intelligent control for the “static switch” which consist of the controlled electronic switching circuit(see Figure 1-2). The loads can be powered by both the inverter output and the bypass input. Under normal conditions, the loads are powered by the inverter whose static switch is closed. In case of overload (beyond the overload time limit) or fault with the inverter, the static switch will automatically switch to the bypass circuit.

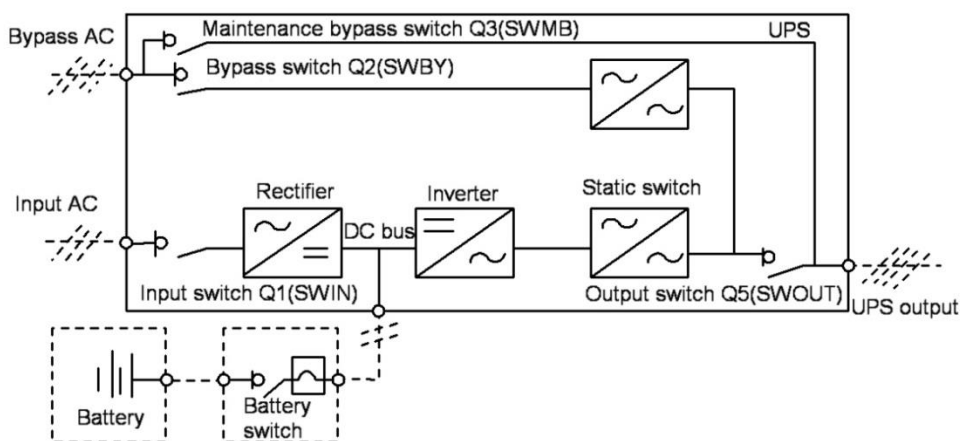

Figure 1-2 UPS switch

In normal conditions, complete synchronization of the inverter output and bypass power is a must for achieving uninterrupted switch between inverter output and bypass power.

Given such requirement, when the bypass power frequency is within the locking range, the inverter output frequency in the inverter-controlled circuit is tracking the bypass power frequency.

What’s more, there is also a manual maintenance bypass switch in the UPS system. When the UPS needs to be shut down for maintenance, the bypass power will directly supply power the important loads via the manual maintenance switch.

Note: When the loads are powered by bypass or maintenance bypass circuit, the power supply is not guaranteed.

1.2.3 System Control Principle

The system control chart is as Figure1-3:

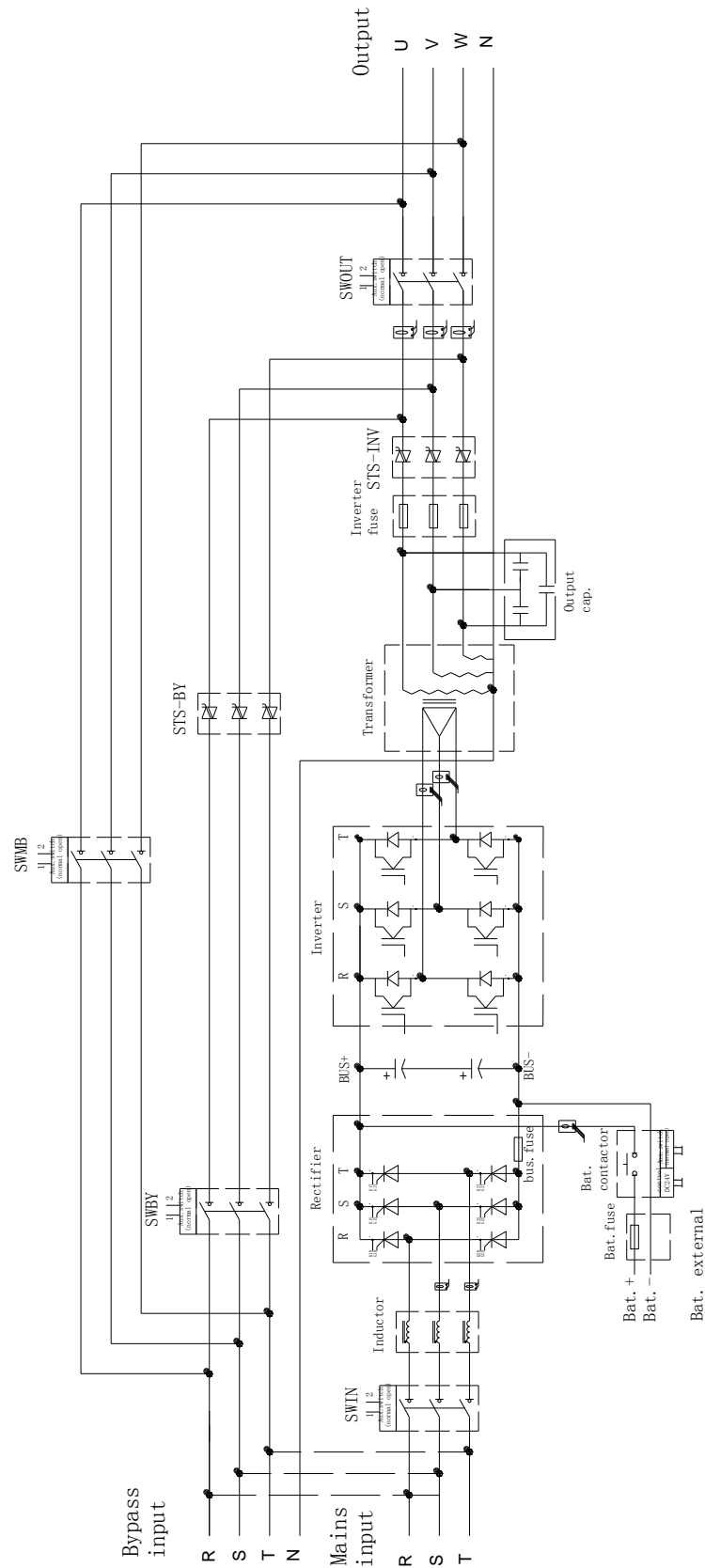

Figure 1-3 UPS system control chart

Normal operation

UPS input AC is normal, the rectifier and the inverter are functioning properly, the loads are powered by the inverter. And battery switch closed, the battery is under the steady floating charge by the DC bus bar voltage.

("1+N" parallel UPS system) Note: As the output of all the UPS stand-alone machines are connected in parallel, the system will check whether all the inverter-controlled circuits are operating synchronously, and whether the frequency and phase are in consistence with those of the bypass circuit. The output of each circuit should stay the same. The current for the loads is evenly supplied by each UPS stand-alone machine. In the course of synchronization, the UPS system will display corresponding warning message.

Only when the above requirements are met will the static switch of the stand-alone machine is closed.

Abnormal AC

In case of AC power failure or abnormality, the rectifier will automatically stop working, and the system will switch to battery inverter output, the backup time depends on the loads and the battery capacity. If the AC is still not back to normal during this period of time, the inverter will automatically stop working, and the UPS operating control panel will display corresponding warning message.

The interruption and recovery of the AC do not disrupt power supply to the loads.

AC Recovery

If the AC recovers within certain time, the rectifier will automatically start (and its output power gradually increases), supply power to the loads and charge the battery, hence no interruption in the power supply.

Disconnecting Battery

In case of a need to detach the battery from the UPS system for maintenance, the external disconnecter can be used. At this moment, except the battery backup function during AC power failure, all the other functions of the UPS and the required steady-state performance indexes are not affected.

Failure with UPS Stand-alone Machine

In case of failure with the inverter, the loads will be automatically powered by the bypass circuit, hence no interruption in output power. Under such condition, please contact the customer service center for technical support.

("1+N" UPS parallel system) In case of failure with certain standalone machine in the parallel system, this machine will quit the parallel system. If the machines left can provide sufficient power to the loads, the system will continue with the power supply, hence no interruption. If the machines left cannot provide sufficient power, the system will switch to the bypass AC for power supply.

Overload

In case of overload with the inverter which goes beyond the required time limit or current range (see table 8-6), the inverter will shut down and the system will automatically switch to the bypass circuit for power supply without interruption. In case the overload falls within the time limit and current range, and when the parallel system can provide sufficient power supply, the system will switch to the inverter for power supply. In case of short circuit, the loads switch to the bypass and the inverter will shut down. The switch is first of all decided by the characters of the protective device used in the system.

For the above two circumstances, the UPS operating control panel displays warning messages.

("1+N" UPS parallel system) The control logic system continuously monitors the power requirement of the loads and controls each UPS standalone machine. If the overload time exceeds the set value and the system cannot provide the loads with sufficient power, the loads will switch to the bypass power. When the load value drops to the point where the system can provide sufficient power, the system will switch to the inverter for power supply.

Maintenance Bypass Circuit

There is another bypass circuit for the UPS system, i.e. the maintenance bypass circuit, which is used to provide a safe working environment for the technical staff when they are carrying out regular maintenance or repair for the UPS system, and also to provide AC power for untreated loads. The maintenance bypass circuit can be manually selected via the bypass circuit switch, and cut off when switched to "OFF".



If the UPS system consists more than two UPS standalone machines connected in parallel, do not use the internal maintenance bypass switch.

Attention: If the input power supply does not have an automatic circuit breaker, the output bus bar and the input bus bar of the closed UPS standalone machine are dangerous for high voltage.

1.2.4 ECO Mode (only suitable for the UPS standalone machines)

Under the ECO mode, the loads are primarily powered by the AC bypass circuit while the inverter is in the bypass state. When the AC exceeds the standard frequency and voltage range (which can be set), the system will switch to the inverter for power supply.

The ECO mode can be set in the operating control panel.

The operating method of the ECO mode is the same as the description in *Chapter 5 UPS Operation Instruction*. Under normal conditions, the loads are powered by the bypass AC. At this time, the inverter power supply indicator is off and the warning shows “bypass power supply”.

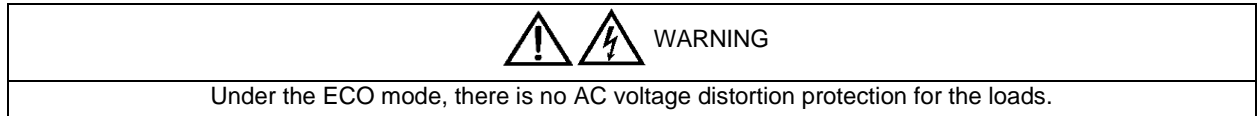

1.2.5 UPS Power Switch Setting

Figure 1-2 is a block chart of the UPS standalone machine with “separated bypass power”. In the separated bypass, the static bypass circuit and the maintenance bypass circuit both have an independent bypass power. Without a separated bypass power, make a short circuit between the input of the bypass switch Q2 and the input of the bypass switch Q1 (for standard machines, there is expected to be a short circuit here) so that the bypass input and the rectifier input use the same AC.

When the UPS is operating properly, all the switches should be closed except the maintenance bypass switch Q3.

1.2.6 System Capacity Expansion

The UPS system can have at most 6 UPS standalone machines connected in parallel. By expanding the capacity, it is able to supply more power to the loads. Capacity expansion should be set or adjusted on the operating control panel of each standalone machines.

Attention: Capacity Expansion should only be carried out by professional staff. The capacity of all the standalone machines should be the same, i.e. the system does not support parallel-connected machines with different capacities.

1.3 Operation Mode

The UPS systems works in one of the following modes:

AC-inverter Power Supply

Mains being converted to DC by the rectifier and inverted to AC by the inverter, the UPS can provide continuous AC power to the loads. Meanwhile, the charger (the rectifier) charges the battery via floating charge or equalizing charge.

Battery

Under the battery mode, the battery, after being inverted by the inverter, provides the loads with backup power. In case of AC failure, the system will automatically switch to the battery mode, hence no interruption in power supply. When AC power recovers, the system will switch back to the AC-inverter mode automatically, and power supply to the loads will not stop.

Automatic Power On

The UPS system offers automatic power on. Specifically, if the AC failure extends too long, the battery discharges till the cut-off voltage and the inverter shuts down. After the AC recovers, after the preset delay time, the UPS will automatically start up. This function and the delay time are set by the commissioning engineer.

Bypass

Under this mode, the loads are powered by the static bypass AC, which can be seen as an intermediate power supply mode when the loads are switching between the inverter power supply and the maintenance bypass power supply. It is also the working mode under abnormal conditions.

Maintenance Bypass

When the UPS is off, the loads are connected to the bypass power via the maintenance bypass switch.

Joint Power Supply

The UPS system offers joint power supply. AC input power together with battery backup power to meet the demand of the loads. It is useful in the occasions which high electricity charge during peak hours or in the occasions where

the oil engine cannot meet the power demand of the loads during the AC failure. Joint power supply can be set by the users, and the share of AC input can be set from 20% to 100%.

ECO Mode (only applicable in the stand-alone system)

All the power switches and battery switches are closed, and the loads are primarily powered by the bypass circuit. When the bypass power is within the normal frequency and voltage ranges, the loads are powered by the bypass circuit and the inverter serves as a backup. When beyond the ranges, the system will switch to the inverter output.

Parallel Redundancy (system capacity expansion)

In order to increase system capacity or reliability, or both, you may set the UPS stand-alone machines to be directly connected in parallel, which ensures even load sharing among all the stand-alone machines through their internal control logic. The parallel system can have at most 6 stand-alone machines connected together.

Frequency Converter

The UPS has a frequency converter mode which offers 50Hz and 60 Hz firm outputs. The input frequency ranges between 45Hz and 65Hz. Under this mode, the bypass switch should be cut off, the static bypass circuit is invalid, and the battery is optional in light of whether there is a need to operate in the battery mode.

2. Mechanical Installation

This chapter briefly introduces the mechanical installation of the UPS, including the do's and don'ts, environment requirements, mechanical requirements, initial check before installation and installation diagram.

2.1 The Do's and Don'ts



Before the commissioning engineer powers on the UPS for debugging, make sure to keep the dust cover on top of the UPS to prevent accumulation of dust in the machine which may result in system failure and safety hazards.



Do not power on the UPS before the commissioning engineer comes.



The installation of the UPS should be carried out according to instructions in the manual by professional engineers. For issues that are not mentioned in the manual. Please refer to the detailed mechanical and electrical installation materials as supplement enclosed in the products.

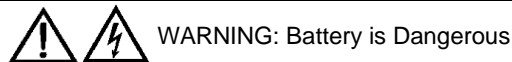

Installing the battery requires enormous carefulness. When the battery is connected, its terminal voltage exceeds 400Vdc, which may lead to electric shock.

1. Please wear eye shield to prevent harm from electric arcs.
2. Please take off your metal accessories like ring, watch and things alike.
3. Use tools with insulated handles.
4. Wear rubber gloves.
5. In case of leakage of the battery electrolyte or damage, the battery must be replaced. Put the discarded battery in an anti-acid container and scrap it according to relevant requirements.
6. If the electrolyte drops on the skin, wash it immediately.



The UPS system can be connected to the neutral and ungrounded power system (i.e. IT system).

This chapter introduces the environment and mechanical requirements for the siting and wiring of the UPS system. Due to the distinctive characteristics of each locale, this chapter does not introduce the detailed installation procedure, but rather offers a general installation procedure and method to the installation staff who may make specific treatments according to the conditions of the locale.

2.2 Environment Requirements

2.2.1 Site Selection for the UPS

The UPS should be installed in a cool, dry, clean and well-ventilated environment. The dust should not have conductive powder (like metal powder, sulfide, sulfur dioxide, graphite, carbon fiber, conductive fiber etc.), acid mist

or other conducting medium (dense ionized materials). Specific environment indicators should meet national standards and regulations, as well as the requirements of this manual. (See table 8-2)

Forced air cooling is provided by the internal fan. The cool air enters the UPS via the air grids of the UPS machine and exhaust through the top of the UPS. If the UPS is installed on the raised floor, with wires connected at the bottom, the cool air may also enter the UPS via the gaps of the floor. Exhaust fan recommended to be installed if necessary to accelerate ventilation in the environment. In an environment where there is much dust, an air filter is needed.

Note1: When the battery is installed near the UPS, the upper limit of room temperature is decided by the battery, not the UPS.

Note2: Under the ECO mode, the power consumption is relatively small. Under the mode of inverter power supply, the power consumption is quite big, which requires appropriate air conditioning.

2.22 Site Selection for the Battery

Temperature is a major factor for the battery capacity and service life. The standard room temperature for the battery is 20°C, above which the service life might be undermined and below which the battery capacity is reduced. Under normal conditions, acceptable room temperature is between 15°C and 25°C. The room temperature should remain constant and the battery should be kept away from heat or major vents.

The battery recommended to be installed in the battery cupboard close to the UPS. If the battery is placed on the raised floor, just like the UPS, a holder is required to be put below the floor. If the battery is placed in the battery shelf or other places away from the UPS, the battery switch should be installed as close to the battery as possible to ensure the shortest wiring.

2.3 Mechanical Requirements

2.31 System Configuration

According to the different design requirements, a UPS system may consist of several equipment cabinets, for example UPS cabinet and battery cabinet. In normal circumstances, all the cabinets are installed abreast of the same height to make them neat.

2.32 Moving the Cabinets

 WARNING
The hoisting equipment must have sufficient ability to lift the UPS cabinets.

Make sure the weight of the UPS is within the loading capacity of the hoisting equipment. See Table 8-3 for the weight of UPS.

The UPS cabinets can be carried by the forklift. Before loaded onto the forklift, remove the grid plates at the bottom, front (or side) of cabinets.

If the forklift is not available, use the rollers.

2.33 Operation Space

There is no fan at both sides of the UPS, hence no special requirement for the space. Please leave a space of 1,000mm for the sake of maintenance operation over the magnetic components at the back. Sufficient room should be left in front of the UPS so that people may freely walk past the UPS with front door open vertically.

2.34 Wiring

The UPS adopts bottom wiring. It is suggested to choose appropriate cable route and proper wiring to ensure that the cables can be smoothly connected to the UPS line bank.

2.4 Initial Check

Before installing the UPS, check the following items:

1. Make sure that the room environment meets the requirements of the product technical specifications, particularly the temperature, ventilation and dust.
2. Unpack the UPS and the battery and have a visual inspection over whether there is any damage within and outside the UPS and the battery. If so, contact the common carrier.

2.5 Installation Diagram

This section introduces the key mechanical characteristics of the UPS cabinets.

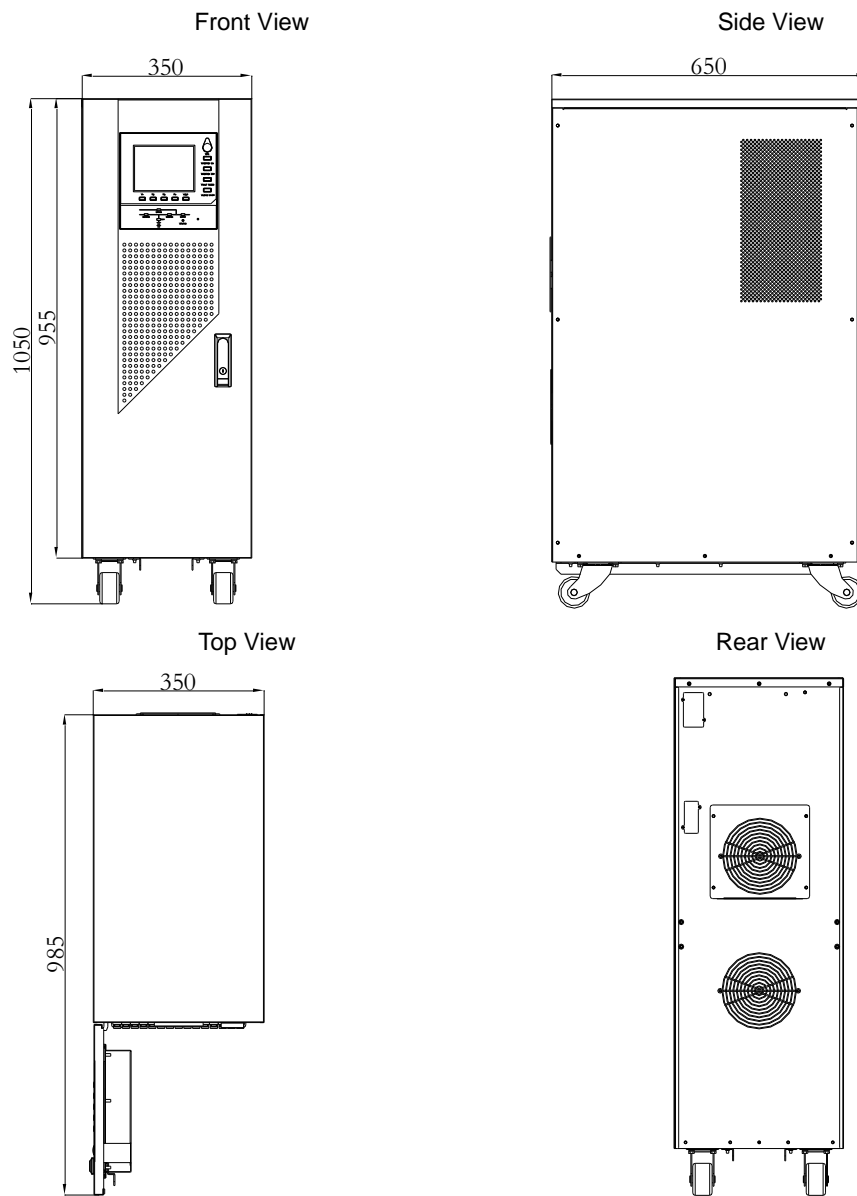

Figure 2-1 10kVA/15kVA/20kVA UPS (6 pulse rectifier) front/side/top/rear view (mm)

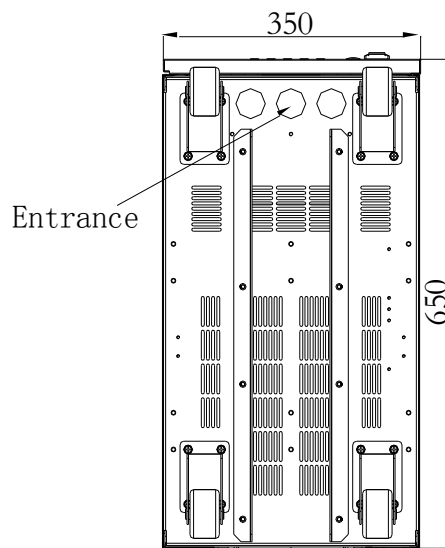

Figure 2-2 10kVA/15kVA/20kVA UPS (6 pulse rectifier) bottom view (mm)

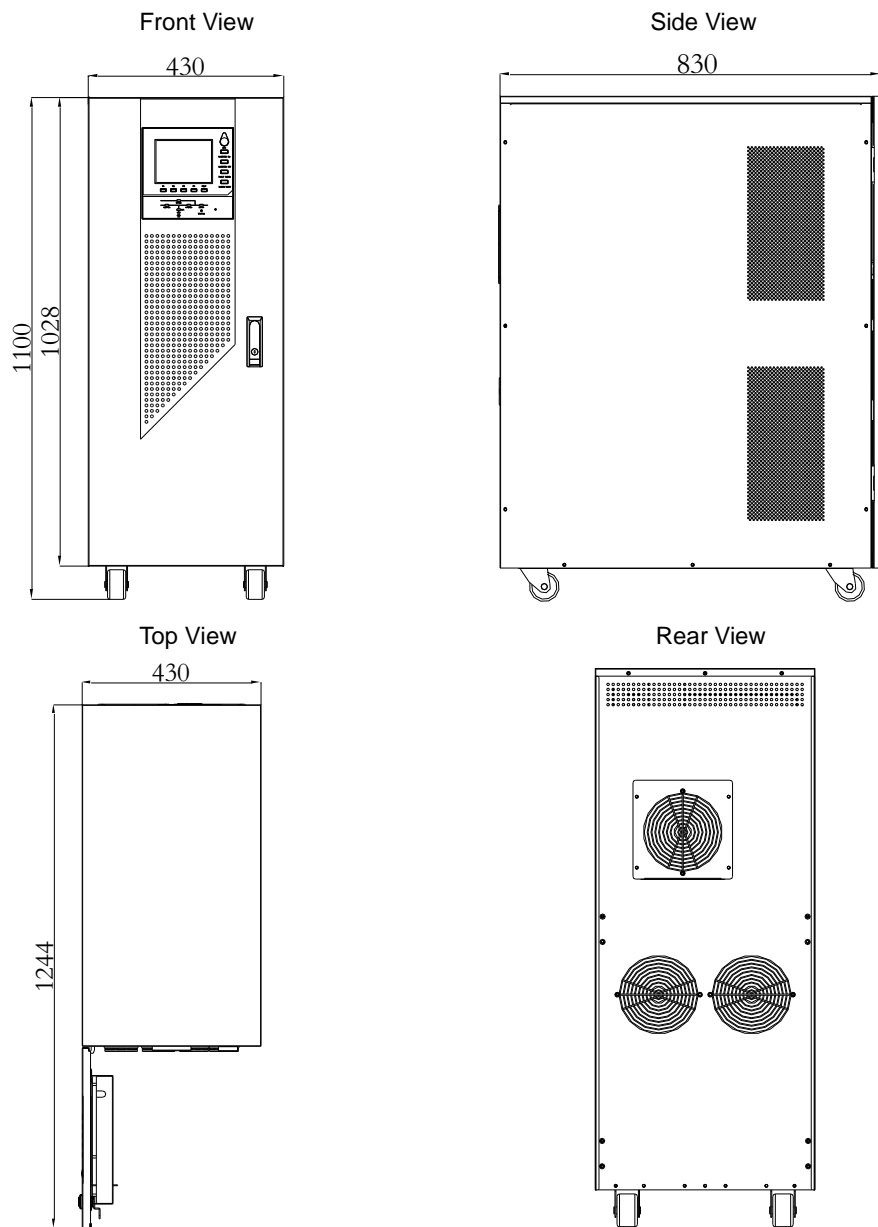

Figure 2-3 30kVA/40kVA UPS (6 pulse rectifier) front/side/top/rear view (mm)

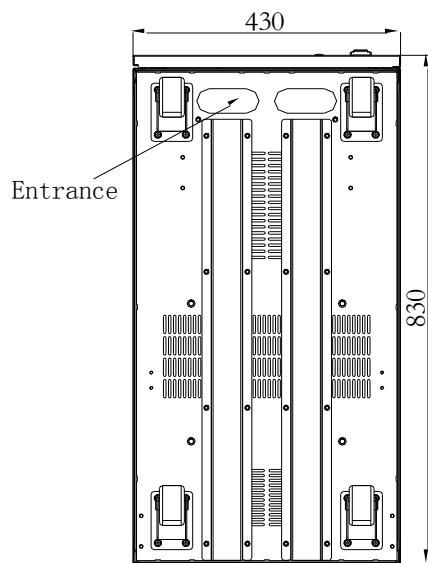

Figure 2-4 30kVA/40kVA UPS (6 pulse rectifier) bottom view (mm)

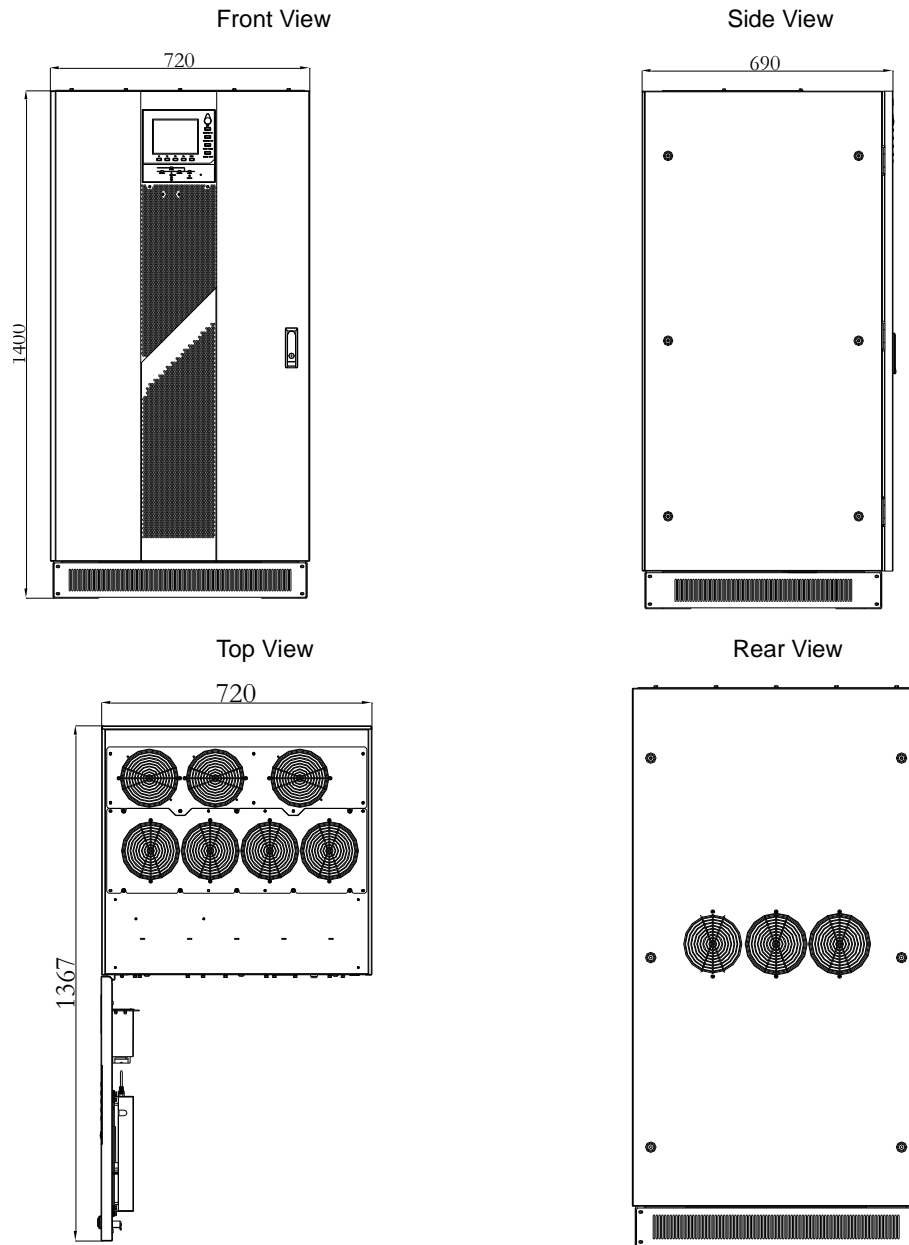

Figure 2-5 60kVA/80kVA UPS (6 pulse rectifier) front/side/top/rear view (mm)

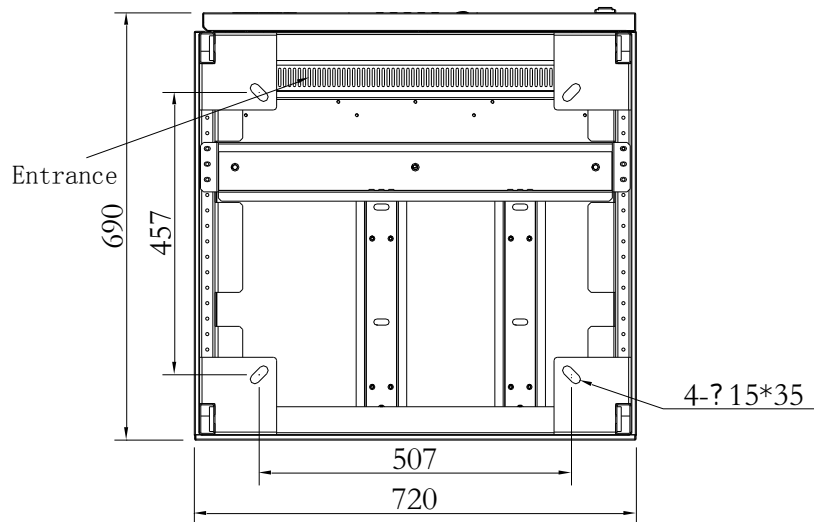

Figure 2-6 60kVA/80kVA UPS (6 pulse rectifier) bottom view (mm)

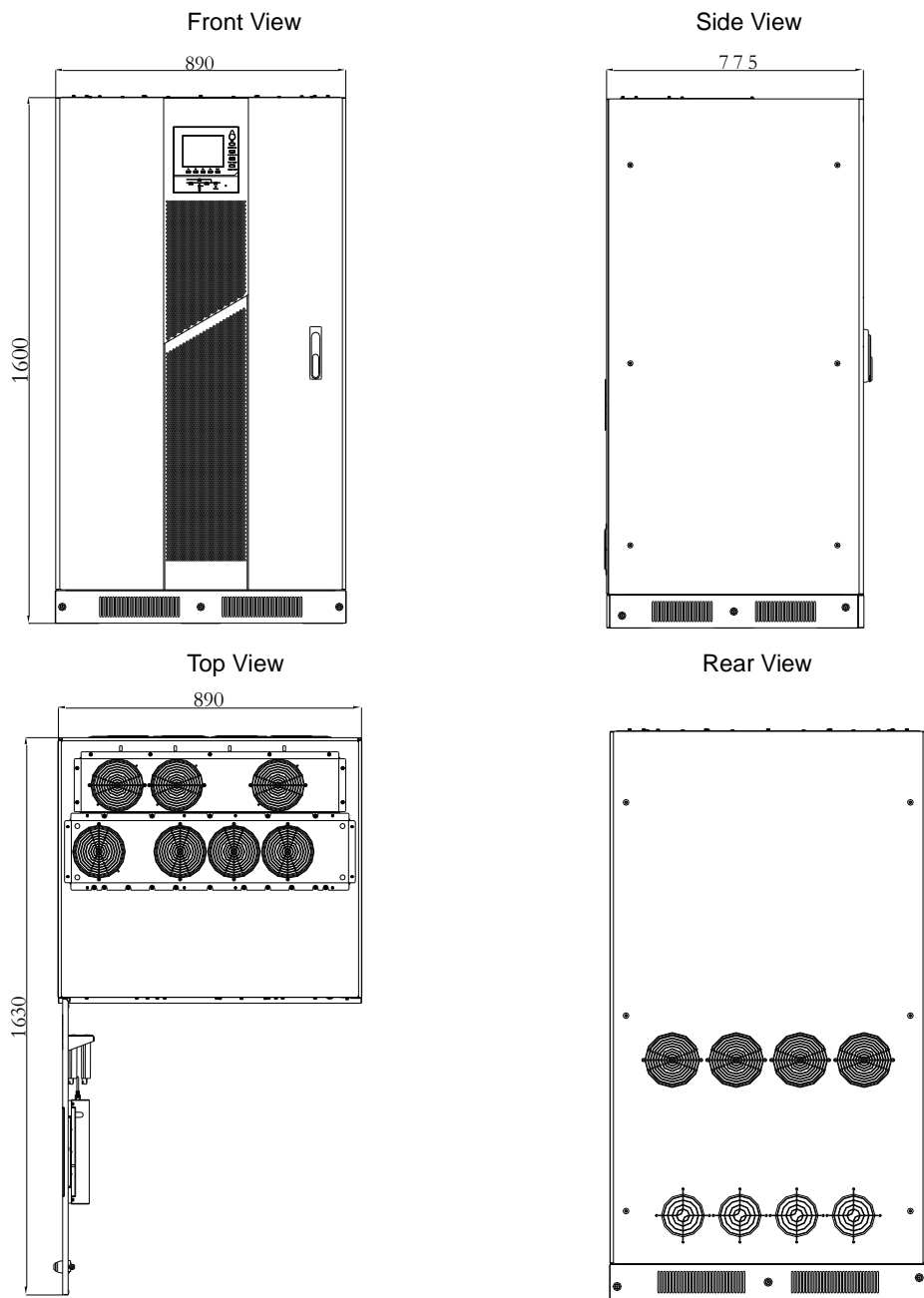

Figure 2-7 100kVA/120kVA UPS (6 pulse rectifier) front/side/top/rear view (mm)

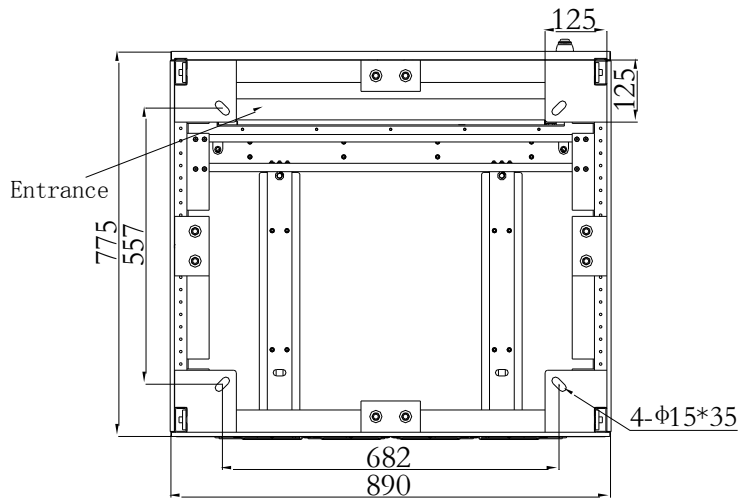

Figure 2-8 100kVA/120kVA UPS (6 pulse rectifier) bottom view (mm)

3. Electrical Installation

This chapter mainly introduces the electrical installation of the UPS, including the procedure and method for connecting the power cable and the control cable, as well as the distance between the equipment connection joint and the floor.

After the mechanical installation of the UPS, it is time to connect the power cables and the control cables. All the control cables, shielded or not, should have separate routing different from the power cables in the metal tubes which are joined with the metal parts of the cabinets.

3.1 Wiring of Power Cables



Before wiring, please double check the switch on the upstream panel connected to the mains input /bypass input /battery input of UPS. Make sure that the switch is off and attach a warning signal to prevent others from turning on the switch.

Please refer to 2.3.4 Wiring Method for cable wiring.

3.11 System Configuration

The wire diameter for the system's power cables should meet the following requirements:

UPS Input Cable

The wire diameter for the UPS input cables varies in light of the UPS power and input AC voltage and should meet the maximum input current requirement, including the maximum battery charging current. See Table 3-1.

UPS Bypass and Output Cable

The wire diameter for the UPS varies in light of the UPS capacity and input voltage level and should meet the maximum input current requirement (max. charging current). See Table 3-1.

Battery Cable

Each UPS is connected with the battery via the positive and negative poles. The wire size for the battery cables depends on the UPS capacity and should meet the max. battery discharge current requirements when the battery voltage is close to the cut-off one. See Table 3-1.

3.12 Cable Specification

The specification for UPS with different powers is listed in Table 3-1.

Table 3-1 UPS Power Cable Specifications

UPS power (kVA)	Rated Current: Amps						Specifications for the stud bolt of the busbar				
	Input AC when the battery is full loaded			Full loaded output			Battery discharging current at the lowest battery voltage (400Vac) *	Input/output cable		Battery cable	Moment of force (Nm)
	380V	400V	415V	380V	400V	415V		bolt	Copper bar		
10	21	20	19	15	14	13	29	M6	M6	M6 bolt	10~12
15	31	30	28	23	22	21	44	M6	M6	M6 bolt	10~12
20	43	41	39	30	29	28	58	M6	M6	M6 bolt	10~12
30	62	59	56	45	43	41	87	M6	M6	M6 bolt	10~12
40	85	81	78	60	58	56	116	M6	M6	M6 bolt	10~12
60	123	118	113	91	87	83	175	M8	M8	M8 bolt	12~15
80	170	162	156	122	118	112	232	M8	M8	M8 bolt	12~15
100	213	203	195	152	145	139	290	M8	Φ9	M8 bolt	12~15
120	246	235	226	181	174	167	349	M8	Φ9	M8 bolt	12~15

Note*: For the 380Vac power input, the maximum battery discharging current increases by 3%;for the 415Vac input, the maximum battery discharging current decreases by 3%.

3.13 The Do's and Don'ts

The following points only offer general guidance. If there are local standards, follow the local standards.

1. The wire diameter for neutral line should be chosen based on 1.5 times of the output/bypass phase current.
2. The wire diameter for the protective ground wire should be chosen based on 2 times of the output/bypass conductor (which depends on the fault level, cable length and protection type etc.).
3. For cables with big current, thinner cables connected in parallel can be used, which may facilitate installation.
4. When choosing the wire diameter for the battery cables, refer to the current value in Table 3-1 and a voltage drop of 3Vdc is allowed.
5. For most installation, particularly the installation of a system with multiple stand-alone machines connected in parallel, the loading equipment is connected with the bus bar power distribution network powered by the UPS, instead of directly connected with the UPS. Under such circumstances, the wire diameter for the UPS output cables should meet the requirements of the output power distribution network, rather than depending on the full load conditions of the stand-alone machines.



3.14 Cable Connector

The rectifier input, bypass, output and battery power cables are connected with the bus bar under the power switch. See Figure 3-2~Figure 3-5.

3.15 Protected Area

There is ground connection near the input and output copper bar, as is shown in Figure 3-2~Figure 3-5. The protective ground wire should be plugged into the ground connection and connected with each cabinet in the system.

All the cabinets and cable troughs should have ground connection according to local requirements. The ground wire should have wire turn secured over a metal bridge to prevent the fastening bolt from loosening when being pulled.

  Warning
If ground connection is not done as required, it may lead to electric shock and fire risk.

3.16 Protector

Out of concern for safety, it is necessary to install a breaker outside the UPS for the input power and battery. As the specific installation conditions vary, the section only offers general information for the installers, including basic knowledge about the operation practice, rules and regulations, equipment installation etc.

Rectifier and Bypass Input Power

1. Input current and short circuit protection

Install appropriate protectors in the AC input distribution line, and the overload capacity of the system should be taken into account. (See Table 8-6 and 8-7)

2. Separate bypass

If the separate bypass is adopted, a protector should be installed at the input AC and bypass AC distribution line respectively. The protector's reference input current should be decided based on the UPS capacity and AC input voltage (See Table 3-1).

3. Ground fault protection

If there is a residual current device (RCD) at the power-connected end, the transient and steady earth leakage current must be taken into account.

There is a RFI filter inside the UPS, thus there is leak current at the protective ground wire, ranging between 3.5mA and 1,000mA.

The residual current circuit breaker (RCCB) must be sensitive to the DC unidirectional pulse (A grade) at the entire distribution network, and should not be sensitive to the transient current pulse. Their symbols are shown in Figure 3-1.

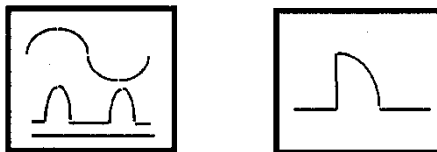

Figure 3-1 Symbols for RCCB

There should be an average sensitivity for the switch which can be adjusted from 0.3A to 1A.

It is suggested to confirm the sensitivity of each RCD at the superior and subordinate power distribution (to the loads).

Battery

Inside the UPS, there is a battery contactor which only has the function of zero-current close down and battery cut off under normal operation. Therefore, it is necessary to install a breaker outside the UPS cabinet to protect the battery and offer necessary safety protection.

The switch is important for the battery maintenance and is usually installed near the battery.

System Output

If there is an independent distribution board at the load end, its protector must be differentiated from that of the UPS output end to ensure protection selectivity.

3.17 Connection Procedure for the Power Line

After the equipment siting is finished, see Figure 3-2 and Figure 3-5 and follow the steps to connect the power line:

1. Make sure that all the switches at the UPS input and all the switches inside the UPS must be cut off. Put a warning sign at the switches to prevent others from operating on the switches.
2. Before opening the front door of the UPS, remove the protective cover plate at the bottom and you can see the connection copper bar.
3. Connect the protected area and other necessary ground cables with the ground copper bar at the bottom of the UPS power equipment.

Note1: The connection for the ground wire and neutral wire must accord with local and national regulations.

Public Input Connection

4. If the bypass circuit and rectifier adopt public input, connect the AC input cables with the UPS main input copper bar (L1A-L2A-L3A-N1 terminal or L1B-L2B-L3B-N1 terminal), and the tightening torques should be set at 13Nm (M8 bolt) and 26Nm (M10 bolt). **Pay attention to the phase sequence.**

Separate Bypass Connection

5. If the system adopts separate bypass circuit, connect the AC input cables with the input copper bar (L1A-L2A-L3A terminal), connect the bypass AC input cables with the bypass copper bar (L1B-L2B-L3B-N2 terminal), and the tightening torques should be set at 13Nm (M8 bolt), 26Nm (M10 bolt) and 50Nm (M12 bolt). **Pay attention to the phase sequence.**

System Output Connection

6. Connect the system output cables to somewhere between the output copper bar (N3-L1-L2-L3 terminal) and the loads, and the tightening torques should be set at 13Nm (M8 bolt), 26Nm (M10 bolt) and 50Nm (M12 bolt). **Pay attention to the phase sequence.**



If the loads have no demand for power during debugging, please proper handle the insulation at the end of the system output cables.

Battery Connection

7. Connect the battery cables somewhere between the UPS terminals (+/-) and the battery switch. **Pay attention to the polarity.**



Do not close the battery switch until the installation is completely finished.

8. Make sure to put back the metal protective cover plate after all the cables are connected.

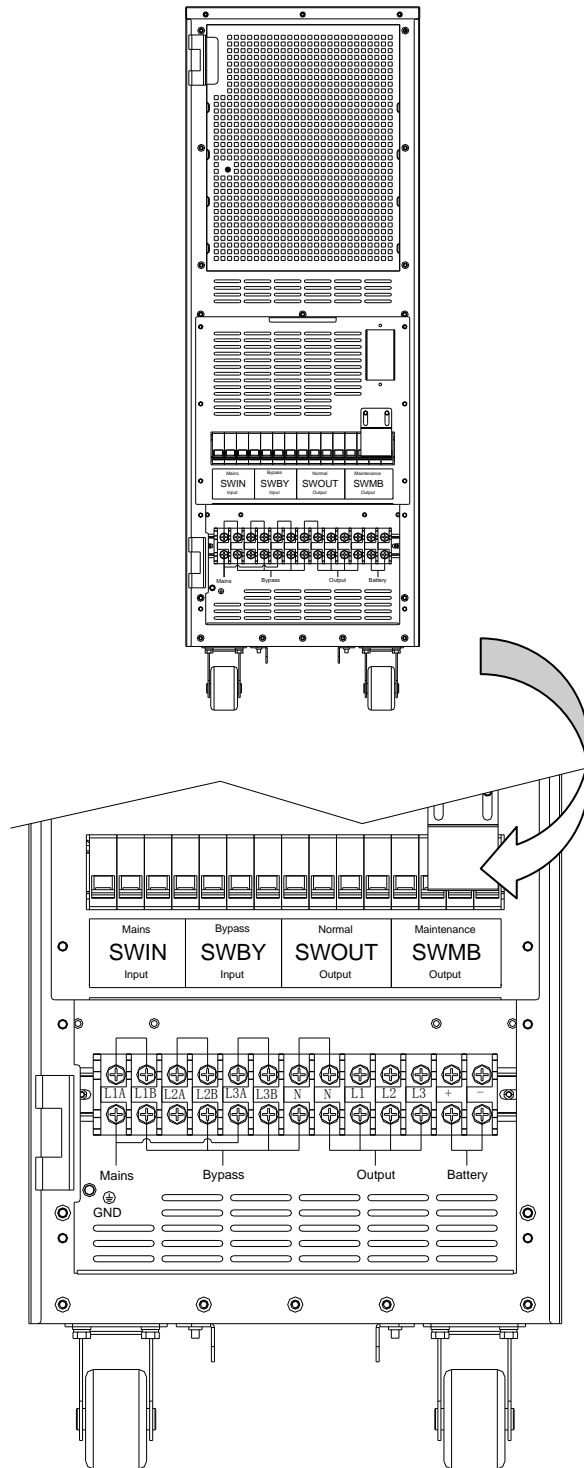

Figure 3-2 10/15/20kVA UPS Power Cable Connection Diagram

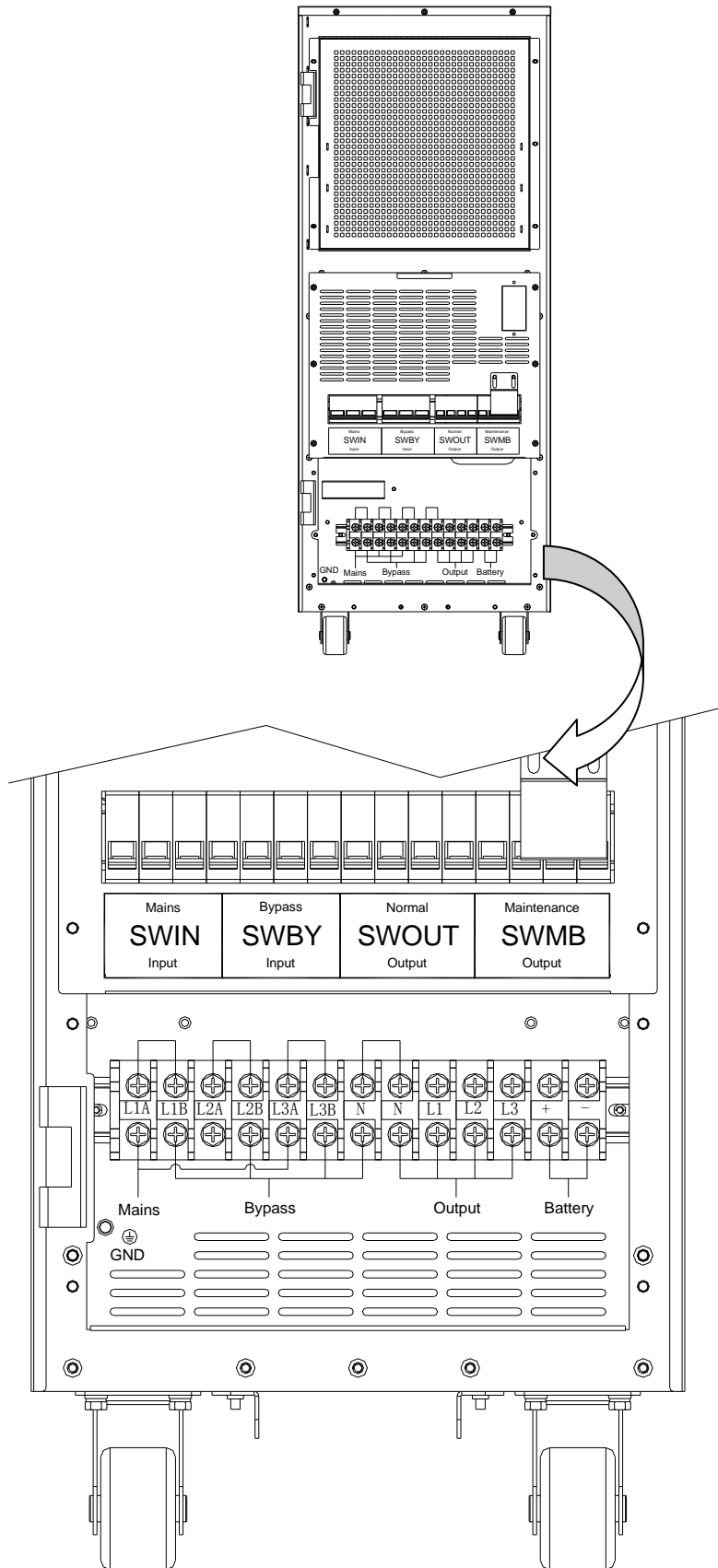

Figure 3-3 30/40kVA UPS Power Cable Connection Diagram

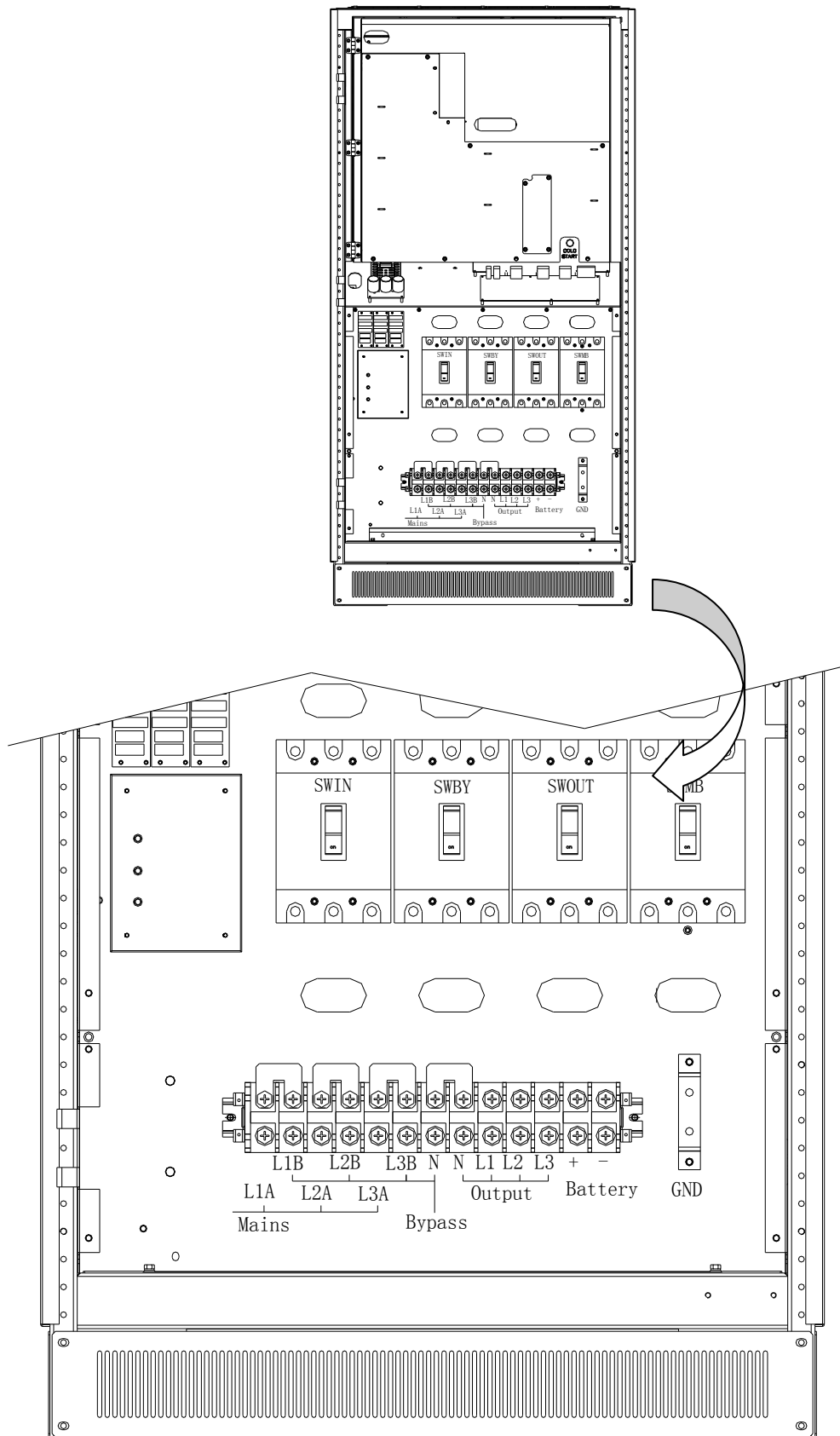

Figure 3-4 60/80kVA UPS Power Cable Connection Diagram

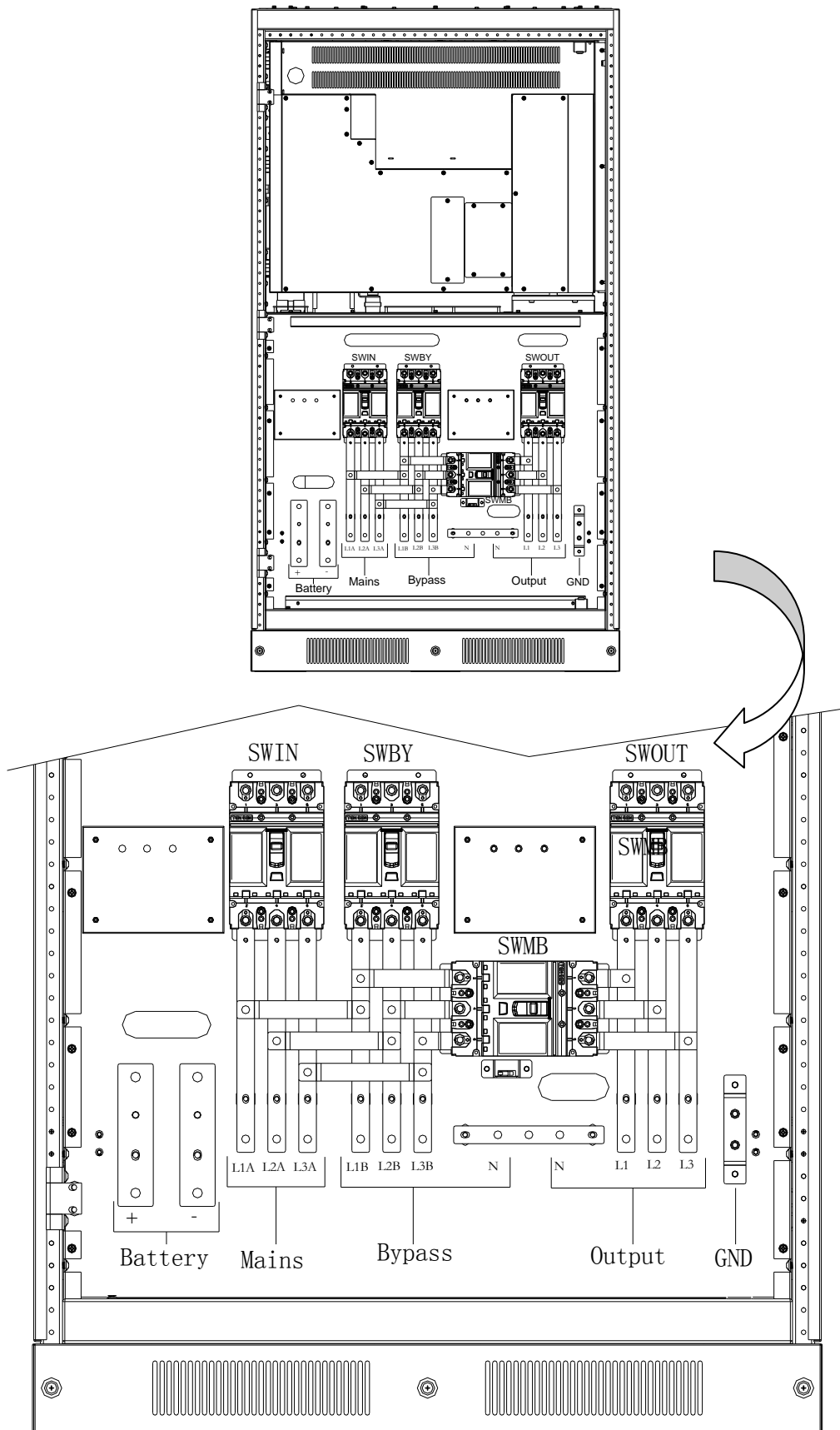

Figure 3-5 100/120kVA UPS Power Cable Connection Diagram

3.2 Distance between the Connection Point and the Floor

See Table 3-2 for the distance between the connection point and the floor.

Table 3-2 Distance between the connection point and the floor

UPS connection point	Minimum distance from the floor (mm)			
	10/15/20KVA	30/40KVA	60/80KVA	100/120KVA
Rectifier AC input power	225	184	250	314
Bypass AC input power	225	184	250	314
UPS AC output	225	184	250	314
Battery cable	225	184	250	253
Grounding bar	178	123	235	304

3.3 Wiring of Control Cables

3.31 Monitor Board Port

In light of specific requirements, the UPS may need auxiliary connection to manage the power system, communicate with PCs, send warning signals to external equipment, and achieve remote shut down etc. These functions are realized via the monitor board behind the front door of the UPS. The monitor board offers the following ports as are shown in Figure 3-7:

- Output dry contact port (X1)
- Emergency power-off input port (X2)
- Auxiliary AC power output port (X5)
- Communication connector: serial port RS232-1 and RS232-2, SNMP card communication port

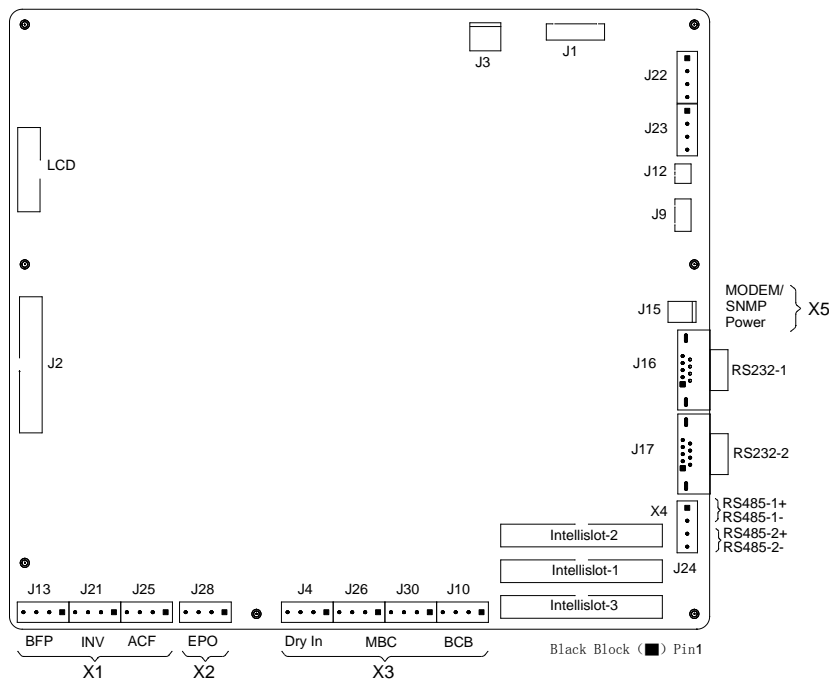

Figure 3-7 Diagram of the ports on the monitor board

Input dry contact port (X3)

Input dry contact port (X3) includes port for battery room environment, battery grounding fault, oil engine power detection (J4) and maintenance bypass cabinet ports (J26, J30), as are shown in Figure 3-8.

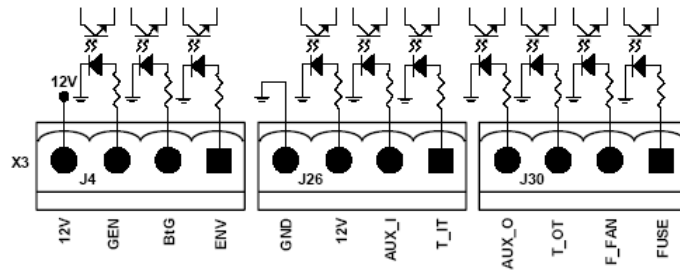

Figure 3-8 Input dry contact port

1. Port for battery room environment, battery grounding fault and oil engine power detection (J4)

See Table 3-3 for a description about the port for battery room environment, battery grounding fault and oil engine power detection.

Table 3-3 Description about the port for battery room environment, grounding fault and oil engine power detection

Location	Label	Meaning
J4.1	ENV ³	Detecting battery room environment (normally closed)
J4.2	BtG	Detecting battery grounding fault (normally closed)
J4.3	GEN ^{1, 2}	Detecting oil engine power supply (normally open)
J4.4	+12V	+12V Power
<p>Note 1: It only becomes valid after setting through the software.</p> <p>Note 2: After setting the dry contact, the charging current limit can be set from 0 to 100% of the full charge current.</p> <p>Note 3: The battery charger will be shut off when the dry contacts are enabled.</p>		

The UPS receives zero-voltage (dry contact) external signal connected with the input dry contact of the phoenix contact J4. Through software setting, the signal is valid when these contacts are connected in short circuit with +12V on the left side of J4. The cables connected with J4 must have separate wiring with the power cables, and the cables should be double insulated cables. The cable size is generally 0.5~1 mm² when the max length 25m~50m.

2. Maintenance bypass cabinet ports (J26, J30)

The maintenance bypass cabinet ports include J26 and J30. The description is shown in Table 3-4.

Table 3-4 Description about the maintenance bypass cabinet ports

Location	Label	Meaning
J26.1	T_IT ¹	Over-temperature for input transformer (normally closed)
J26.2	AUX_I	(Reserved)
J26.3	+12V	+12V Power
J26.4	GND	Power ground
J30.1	FUSE	(Reserved)
J30.2	F_FAN	Fan fault warning (normally closed)
J30.3	T_OT ¹	Over-temperature for output transformer (normally closed)
J30.4	AUX_O	(Reserved)
<p>Note1: It only becomes valid after setting via the software.</p>		

Output dry contact port (X1)

X1 ports offer three relay output dry contact signals. The pin distribution of the dry contact ports is shown in Figure 3-9, and the port description is shown in Table 3-5.

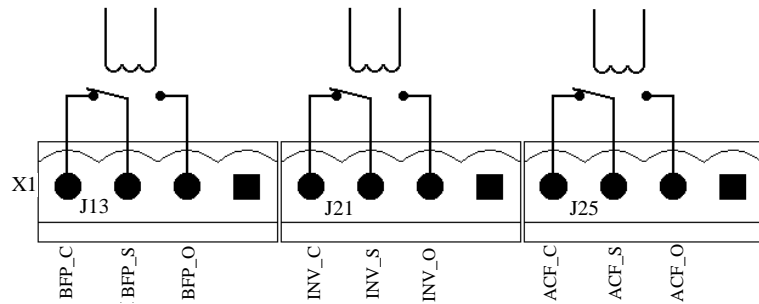

Figure 3-9 Output dry contact ports

Table 3-5 Description about the output dry contact ports

Location	Name	Significance
J13.2	BFP_O	Dry contact for bypass reverse protection (normally open)
J13.3	BFP_S	Relay central point for bypass reverse protection
J13.4	BFP_C	Dry contact for bypass reverse protection (normally closed)
J21.2	INV_O	Dry contact relay for inverter power supply (normally open)
J21.3	INV_S	Central point of the dry contact relay for inverter power supply
J21.4	INV_C	Dry contact relay for inverter power supply (normally closed)
J25.2	ACF_O	Dry contact relay for abnormal input voltage or frequency in the main circuit (normally open)
J25.3	ACF_S	Central point of the dry contact relay for abnormal input voltage or frequency in the main circuit
J25.4	ACF_C	Dry contact relay for abnormal input voltage or frequency in the main circuit (normally closed)

⚠	Warning
All the auxiliary cables must be double insulated stranded cables whose sectional area is 0.5~1.5 mm ² .	

Emergency Power-off Input Port (X2)

The UPS offers the function of emergency power-off (EPO) which can be achieved by the EPO button at the front door of UPS or the remote contact by the users.

Figure 3-10 shows that X2 port with remote EPO input contact. The port description is shown in Table 3-6.

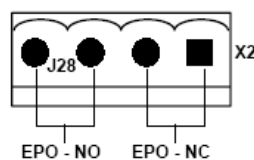



Figure 3-10 Emergency Power-off Input Port

Table 3-6 EPO Input Contact Relay

Location	Name	Meaning
J28.1	EPO_NC	EPO enable when disconnected with J28.2
J28.2	EPO_NC	EPO enable when disconnected with J28.1
J28.3	EPO_NO	EPO enable when connected with J28.4

J28.4	EPO_NO	EPO enable when connected with J28.3
-------	--------	--------------------------------------

The cable, which connected the external equipment for emergency power-off to remote dry contact EPO terminals (N.C. or N.O.), should be shielded. If there is no need for the function, cut off pin 3 and 4 for J28, and create short circuit between pin 1 and 2 of J28.

 Attention
When the EPO is triggered, the rectifier, inverter and static bypass circuit will be closed down, but the AC input connected to input terminal of the UPS is not cut off. If it is necessary to completely power off the UPS, turn off the upstream input switch while enable the EPO function.
Upon delivery, pin 1 and pin2 on the normally-closed contact J28 have short circuit.

Auxiliary DC power output port (X5)

Auxiliary DC power output port X5 offers auxiliary DC power for SNMP card. The voltage ranges between 9V and 12V; the maximum current is 500mA.

Communication port

Communication ports include serial port RS232-1, RS232-2, and Intellislot smart communication port.

1. Serial port RS232-1 and RS232-2

RS232-1 offers serial data and is used as the UPS monitor software port.

RS232-2 offers serial data and is used as the debugging and maintenance port for commissioned debugging and maintenance personnel.

2. Intellislot smart communication port

The UPS offers three Intellislot smart communication ports (Intellislot 1, Intellislot 2, Intellislot 3) used for installing SNMP card, UPS JBUS/MODBUS adapter card and dry contact card.

See Table 3-7 for common communication resources of serial RS232-1, RS232-2 and Intellislot smart communication ports.

Table 3-7 Resource distribution for communication ports

Port	Menu setting on LCD screen	Monitor equipment support	Baud rate	Note
Intellislot 2	Baud rate setting for serial port 1	SNMP card	9600bps	Cannot be used with RS232-1 at the same time
Intellislot 1	Baud rate setting for serial port 2	SNMP card	9600bps	Cannot be used with RS232-2 at the same time
Intellislot 3	Baud rate setting for serial port 3	SNMP card	9600bps	Cannot be used with RS485-2 at the same time
RS232-1	Baud rate setting for serial port 1	Client monitor software	9600bps	-
RS232-2	Baud rate setting for serial port 2	Debugging and maintenance software (only for debuggers and maintenance personnel)	9600bps	Cannot be used with Intellislot2 smart communication port at the same time
RS485-1	Baud rate setting for serial port 1	RESERVED		
RS485-2	Baud rate setting for serial port 3			Cannot be used with Intellislot3 smart communication port at the same time

3. Serial port RS485

RS485 (X4), for 485 communication(optional: modbus protocol). The cable must be shielded twisted pair.

X4

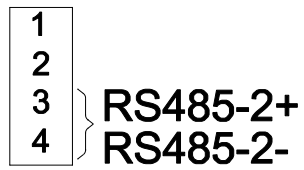

Figure 3-11 Serial port RS485

4. Display Panel of Operation Control

This chapter offers a detailed introduction about the function and usage of different components of the UPS operational control display panel, and LCD display information, including the type of the LCD display screen, detailed menu information and prompt window information, and UPS alarm message list.

4.1 Introduction

The UPS display panel of operation control, located at the front of the machine, is used to control the UPS operations and query all of its parameters, including battery status, event log and alarm messages.

The display panel of operation control can be divided into three parts by function: serial number of the machine and its analog circuit diagram, LCD display and menu keys, and the EPO button and control buttons. The above three parts by function and name of the panel can be seen in Figure 4-1 below.

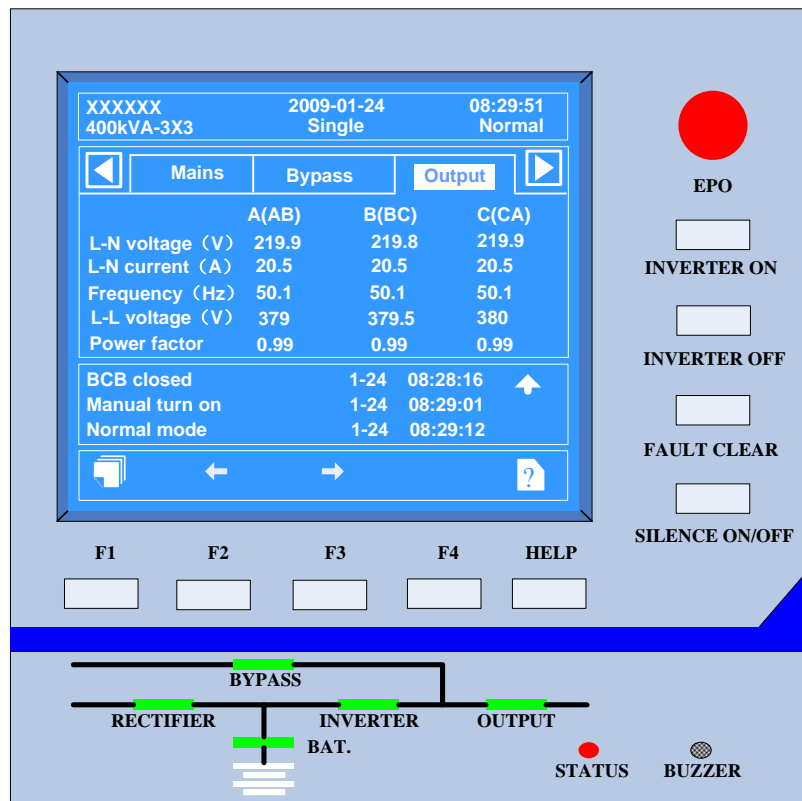

Figure 4-1 UPS Display Panel of Operation Control

4.11 LED Indicator

In the simulative current diagram, six indicators are provided to display the power supply path of the UPS. Each indicator reveals the current running and alarm status of the UPS by changing its color (red, green and yellow) and status (light on, light off and flicker). Status indications of each indicator are described in Table 4-1 below.

Table 4-1 Status Indicated by LED indicators

Indicator	Status	Indication
Rectifier Indicator	Green light keeps on	Rectifier works normally
	Green light flickers	AC is normal, but rectifier is not working
	Red light keeps on	Rectifier breaks down.
	Light off	Rectifier does not work, with abnormal AC current
Bypass Indicator	Green light keeps on	Bypass provides loads with power supply

	Red light keeps on	Bypass power supply is abnormal or beyond normal range; or abnormality occurs to the bypass switch
	Light off	Bypass is normal, but does not provide loads with power supply
Battery Indicator	Green light keeps on	The battery provides loads with power supply
	Green light flickers	Forewarn the end of battery discharge
	Red light keeps on	Abnormality occurs to the battery (battery fault, no battery or reversed battery connection) or the battery switch
	Light off	The battery is getting charged, with normal battery and battery switch
Inverter Indicator	Green light keeps on	Inverter provides loads with power supply
	Green light flickers	Inverter starts up, operates, synchronizes, or is in the stand-by state (ECO mode)
	Red light keeps on	Inverter breaks down
	Light off	Inverter does not work
Output Indicator	Green light keeps on	Output of UPS is normal
	Red light keeps on	Output of UPS over-load
	Light off	No output
Alarm (STATUS) Indicator	Green light keeps on	Normal running
	Yellow light keeps on	UPS alarm (e.g. abnormality of the main path voltage)
	Red light keeps on	UPS failure (e.g. blown fuse of the main path or other hardware failures)

4.12 Alarm Buzzer

The simulative current diagram is equipped with an alarm buzzer. There are three types of alarm according to different status which are described in Table 4-2.

Table 4-2 Description of the Buzzer Alarm

A single short buzz of alarm	Press any function key to send the alarm
A buzz of alarm every other second	In case of UPS warnings (e.g. abnormality in the main path voltage), such alarm will be sent
Continuous buzz of alarm	In case of UPS failure (e.g. blown fuse of the main path or other hardware failures), such alarm will be sent.

4.13 Control Buttons

The display panel of operation control offers four control buttons, whose functions are described in Table 4-3 below.

Table 4-3 Function Description of Control Button

Control Button	Function Description
INVERTER ON	Press this button to start the inverter. Attention: If the inverter is not ready, UPS will not get started when pressing this button.







INVERTER OFF	When the machine is running, press this button to turn off the inverter, with load power transferring to the static bypass.
FAULT CLEAR	In case that UPS is off because of failure and alarm conditions are removed, press this button to clear the fault.
SILENCE ON/OFF	When an alarm is activated, press this button once for silence of the alarm buzzer. If a new fault occurs, the buzzer will send an alarm once again. In case that the buzzer fails to give an alarm, press this button to test the sounds of alarm.

 Attention
To properly activate the above control buttons, press the buttons for about 2 seconds until a short beep is sent.

4.14 LCD and Menu Button

The display panel of operation control offers a LCD screen and five menu buttons (F1, F2, F3, F4 and HELP). Function description of each button can be seen in Table 4-4 below.

Table 4-4 Function description of LCD menu keys

Key	F1	F2	F3	F4	HELP
Function 1	 Window Switch	 Left Shift	 Right Shift	 Enter	 Help
Function 2	ESC ESC	 PageUp	 PageDown		

LCD display interface is user-friendly. With the help of LCD display interface and easy-to-use menu-driven operating system, it is convenient to get the parameters of input/output/load/battery status of the UPS and acquire the current status and alarm messages of the UPS timely, and conduct relevant function setup and control operations. Moreover, the LCD can provide at most 512 historical alarm records for users to query, which serve as a credible basis for fault diagnosis.

As is shown in Figure 4-2, the main LCD display screen consists of five display windows: system information window, menu window, UPS data window, current record window and keyboard description window. Press F1 to switch windows that users have access to.

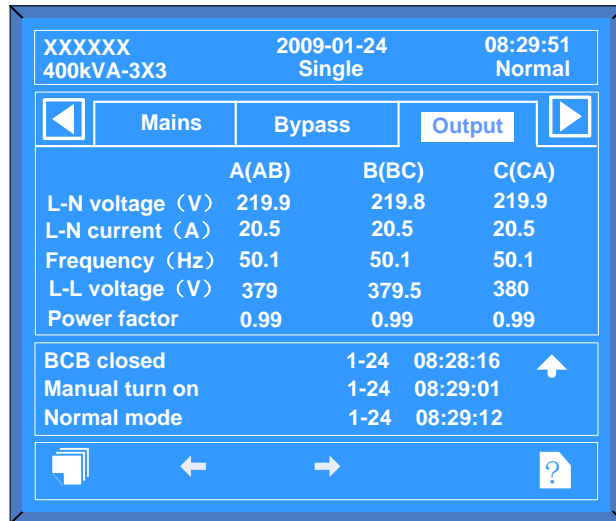

Picture 4-2 Main LCD display screen

4.15 Detailed Menu

A detailed description of the main LCD display screen shown as Picture 4-2 is as follows.

① System Information Window

The UPS system information window displays its basic information, including the current time, date, UPS designation and its configuration and status. A detailed description can be seen in Table 4-5.

Table 4-5 Description of the System Information Window

No.	Display Content	Description
1	XXXXXX	UPS designation
2	2009-01-24	Current date
3	08:29:51	Current time
4	400kVA-3x3	400: the capacity of UPS being 400kVA 3x3: UPS of three-phase input and three-phase output system
5	(Configuration) stand-alone online/stand-alone ECO/parallel system(1#)	Stand-alone online: configuration of UPS being stand-alone system Parallel system (1#): parallel with the #1 of the at most 6 devices Stand-alone ECO: UPS of stand-alone system, running in economic mode (ECO)
6	(Status) normal/alarm/fault	Normal: UPS of normal status, inverter with loads, and no alarms Alarm: A general alarm occurring to UPS Fault: A serious fault occurring to UPS

② Menu Window and ③ UPS Data Window

The menu window displays the items of the UPS data window; while the UPS data window displays relevant item descriptions of selected items in the menu window. Through the menu window and UPS data window, users can get and set relevant UPS parameters. A detailed description is shown in Table 4-6.

Table 4-6 Detailed description about the menu window and UPS data window

No.	Menu	Menu Items	Description
1	Main path input	Line voltage (V)	Line voltage
		Phase current (A)	Phase current
		Frequency (Hz)	Input frequency

No.	Menu	Menu Items	Description
2	Bypass input	Phase voltage (V)	Phase voltage
		Frequency (Hz)	Bypass frequency
		Line voltage (V)	Line voltage
3	AC output	Phase voltage (V)	Phase voltage
		Phase current (A)	Phase current
		Frequency (Hz)	Output frequency
		Line voltage (V)	Line voltage
		Power factor	Power factor
4	Local load	Apparent power (kVA)	Apparent power
		Active power (kW)	Active power
		Reactive power (kVAR)	Reactive power
		Percentage of load	Percentage of UPS rated load
		Crest ratio	Crest factor of the output current
5	Parallel load	Apparent power (kVA)	Apparent power
		Active power (kW)	Active power
		Reactive power (kVAR)	Reactive power
		Stand-alone system without parallel data	In case of stand-alone configuration, UPS has only the local load, with no system load.
6	Battery snap	Battery voltage (V)	Bus voltage of the battery
		Battery current (A)	Bus current of the battery
		Battery temperature (°C)	Internal temperature of the battery (°C)
		Time remaining (min)	Remaining working time of the battery
		Equalizing charge	The battery is in the course of equalizing charge.
		Floating charge	The battery is in the course of floating charge.
		Battery not connected	The battery is not connected.
7	History	<p>.....</p> <p>Abnormity with the inverter output voltage</p> <p>20-01-2009 11:30:02</p> <p>22-01-2009 13:38:06</p> <p>Battery maintenance needed</p> <p>22-01-2009 13:38:02</p> <p>22-01-2009 13:38:36</p> <p>.....</p>	<p>At most 512 UPS historical alarm records can be displayed, with the start time and end time of each alarm annotated.</p> <p>The history record can scroll on the LCD display.</p> <p>For the alarm message list of the UPS operational control display panel, please refer to Table 4-8.</p>

No.	Menu	Menu Items	Description
8	Menu language	Chinese/English	Users can choose either language as the menu display language on the LCD screen. Press F1, PageUp and PageDown (F2, F3) to select this menu item, and press F4 to enter. Press LeftShift and RightShift (F2, F3) to select the language, and press F4 to enter.
9	Function setup	Display contrast	Adjust the display contrast of theLCD. Press F1, PageUp and PageDown (F2, F3) to select this menu item, and press F4 to enter. Press LeftShift and RightShift (F2, F3) to select the desirable value, and press F4 to enter.
		Date format setup	Select one date format: year/month/day, day/month/year, month/day/year. Press F1, PageUp and PageDown (F2, F3) to select this menu item, and press F4 to enter. Press LeftShift and RightShift (F2, F3) to select the desirable value, and press F4 to enter.
		Date and time	Set the date (in the format that users set) and time (in 24-hour time system). Press F1, PageUp and PageDown (F2, F3) to select this menu item, and press F4 to enter. Press PageUp (F2, to select the desirable number) and RightShift (F3, to shift to the next unit) to input the desirable value. With all setup finished, press F4 to enter.
9	Function setup	Communication mode	Set the communication mode (modem function reserved). RS232 for default setting.
		Control password setting	The password is used when operating the "Test command" menu. Press F1 to select "Control password setting", and press F4 to enter. Following the prompts, press PageUp (F2, to select the desirable number) and RightShift (F3, to shift to the next unit) to enter the old password, and press F4 to confirm. Enter a new password in the same way by following the prompts.
10	Test command*	Battery maintenance test	Manually start the battery maintenance test. In the process, the battery will partially discharge for a rough evaluation of the battery capacity. To meet the test requirements, the load must be between 20% and 80%; and the battery must have just been in the course of a floating charge for more than 5 hours continuously. Press F1, PageUp and PageDown (F2, F3) to select the desirable test, and press F4 to enter. Use PageUp (F2, to select the desirable number) and RightShift (F3, to shift to the next unit) to enter the password. Then press F4 to confirm.

No.	Menu	Menu Items	Description
		Battery capacity test	Manually start the battery capacity test. In the process, the battery will fully discharge for a precise evaluation of the battery capacity. To meet the test requirements, the load must be between 20% and 80%; and the battery must have just been in the course of a floating charge for more than 5 hours continuously. Use F1, PageUp and PageDown (F2, F3) to select the desirable test, and press F4 to enter. Use PageUp (F2, to select the desirable number) and RightShift (F3, to shift to the next unit) to enter the password. Then press F4 to confirm.
		System test	Manually start the system test (i.e. UPS self-detection). After the system test proceeds for about 5 seconds, a window will be popped up on the LCD display screen to show the test result: No faults detected, Fault or Alarm.
		Stop testing	Manually stop the battery maintenance test, battery capacity test or system test.
		Force an equalizing charge	When the battery is not in the course of equalizing charge, manually initiate a forced equalizing charge for the battery. Use F1, PageUp and PageDown (F2, F3) to select this function, and press F4 to enter. Use PageUp (F2, to select the desirable number) and RightShift (F3, to shift to the next unit) to enter the password. Then press F4 to confirm.
		Stop a forced equalizing charge	Manually stop a forced equalizing charge for the battery.
11	System version	Monitoring software version: Vxxx Rectifying software version: Vxxx Inverting software version: Vxxx	It offers UPS firmware versions, including the inverter, rectifier and monitor software versions etc.
		UPS version	It offers UPS version information, e.g. 380V-50Hz.
Note*: Users can enter this menu only with the correct password. The initial password is "12345". Please enter "function setup" and select "control password" to reset the password. If the password is lost, please contact the local customer service center of our company.			

④Current Record Window

This window displays the current alarm data of the UPS in detail, with no records of the transient situation already resolved. Use F1, F2 and F3 to browse. For a complete history, please refer to the "History" menu in Table 4-6. For the alarm message list of the UPS, please refer to Table 4-8.

⑤Keyboard Description Window

It uses symbols to describe the function of relevant menu buttons in the specific current window.

4.16 EPO Button

As is shown in Figure 4-1, the UPS display panel of operation control offers an EPO button. To avoid false operation, the EPO button is covered by a safety guard. Press the EPO button for 2 seconds, then all static switches will be locked up (with load power supply cut off); the rectifier and inverter will turn off; and the battery switch will trip out. Normally, since the UPS adopts a manually-closing input breaker, EPO cannot cut off the input power supply of the UPS. If the front-end input of the UPS adopts a switch which trips through electronic control, use this EPO switch driver to make the external breaker trip out, thus cutting off the input power supply of the UPS

4.2 Prompt Windows

Prompt windows will pop up during operation when the system warns users to notice certain status, to confirm a command or conduct other operations. See Table 4-7.

Table 4-7 Annotation of LCD prompt windows

No.	Prompt Information	Annotation
1	Transfer with interrupt, confirm or cancel	The inverter does not synchronize with the bypass power supply. Load switch between bypass and inverter will lead to transient load power interruption.
2	The load is too high to be transferred with interrupt	The parallel system can switch to inverter output from bypass (with load power supply interrupted), only when the total load is less than the stand-alone capacity.
3	This operation leads to output shutdown, confirm or cancel	In case of bypass abnormality, UPS will have no output if users shut down the inverter. Wait for users to confirm or cancel.
4	This operation leads to inverter overload, confirm or cancel	Shutdown of this inverter will lead to overload of other inverters in the parallel system. Wait for users to confirm or cancel.
5	Turn on more UPS to carry current load	The inverter, which has switched on in the parallel system, is insufficient to hold the current bypass load. Users need to turn on more UPSs.
6	Battery will be depleted, confirm or cancel.	If users select the battery capacity test, the battery will discharge until the UPS shuts down, when the system pops up this prompt window for users to confirm. Press cancel to stop the battery discharge, and restore AC inverter power supply.
7	System selftest finished, everything is ok	No operations needed.
8	System selftest finished, please check the current warnings	Check the message on the current record window.
9	Enter control password	The control password must be entered to conduct battery or UPS tests (default password of "12345").
10	Battery selftest condition is low, please check	Fail to meet the requirements for battery test. Users should check whether the battery is in the course of an equalizing charge and whether the battery load meets the condition. To properly conduct a battery test, the load must be between 20% and 80%.

4.3 UPS Alarm Message List

Table 4-8 provides a complete list of all UPS alarm messages, which are included in the "History" menu in *4.1.5 Detailed Menu* and can be displayed in the current record window.

Table 4-8 UPS alarm message list

Alarm message	Annotation
Rectifier comm. fail	RS485 communication between the internal monitor and the rectifier fails.
Mains volt. abnormal	AC voltage exceeds the normal range, which leads to shutdown of the rectifier. Please check the input-phase voltage.
Mains undervoltage	AC undervoltage. Please check the input-line voltage.
Mains freq. abnormal	AC frequency exceeds the normal range, which leads to shutdown of the rectifier. Please check the input voltage and frequency.
Battery fuse fail	With the battery fuse blown out, the battery switch trips.
Rectifier overtemp.	Over-temperature of the radiator leads to breakdown of the rectifier. UPS can automatically recover. Check the environment and ventilation.
Input fuse fail	With the input fuse blown out, the rectifier shuts down.
Control power 1 fail	The UPS operates, but abnormality occurs to the control power supply or there is no control power supply.
Control power 2 fail	The UPS operates, but abnormality occurs in the redundancy control power supply, or there is no redundancy control power supply.
Mains phase reversed	Reversed phase of the main path input
Rectifier current limit	Over-current of the rectifier leads to over-power operation.
Soft start fail	Due to low DC bus voltage, the rectifier fails to start.
REC drive circuit fault	Due to abnormal connection of the drive cables or incorrect type setting of the rectifier, the rectifier shuts down.
REC input Ph. missing	Phase loss of the main path input. Check the wiring of the input power supply. And examine whether AC flashes abnormally.
DC bus over voltage	DC bus over-voltage leads to shutdown of the rectifier and inverter. Check whether faults occur to the rectifier.
Bus capacitor overvolt	With the voltage for bus capacitor exceeding 350V, the rectifier shuts down. Check the capacitor voltage of the two bus bar.
EPO	Emergency power-off: when users directly press the EPO button on the operational control display panel, or when the device receives an external order of emergency power-off.
Input disconnect open	The main path input switch is opened.
Input disconnect closed	The main path input switch is closed.
No battery	Check the battery and its wiring. Then examine whether the battery switch is closed, and whether its dry contact is connected.
Auto start	When battery discharge is done, the UPS will shut down. The inverter will automatically power on once AC recovers.
Generator connected	The generator is connected.
BCB open	A status of the battery contactor (opened)
BCB closed	A status of the battery contactor (closed)
Battery float charging	A status of the battery (in the course of float charge)
Freshening charge	A status of the battery (in the course of even charge)
Battery discharging	A status of the battery (discharging)
Battery period testing	An automatic battery maintenance discharge test is proceeding at regular intervals (with 20% capacity discharging).
Batt. capacity testing	Users start the battery capacity discharge test (with 100% capacity discharging).
Batt. maint. testing	Users start the battery maintenance discharge test (with 20% capacity discharging).
Inverter in setting	The inverter is starting and synchronizing.
Rectifier in setting	The rectifier is starting and synchronizing.
Battery Room Alarm	Caution the environment of the battery room.
REC FLASH UPDATE	The rectifier software is being upgraded.
INV FLASH UPDATE	The inverter software is being upgraded.
MONITOR FLASH UPDATE	The monitor software is being upgraded.
Unit off confirm	Users press Enter (F4) to shut down the stand-alone in the parallel system based on the prompt.
System off confirm	Users press Enter (F4) to shut down the parallel system based on the prompt.

Alarm message	Annotation
Fault reset	Press the key of FAULT CLEAR on the display panel of operation control.
Alarm silence	Press the key of SILENCE ON/OFF on the display panel of operation control.
Turn on fail	The inverter fails to start manually, which may be caused by invalid operation (the maintenance bypass switch closed), with the DC bus or the rectifier not prepared.
Alarm reset	Press the key of FAULT CLEAR or that of SILENCE ON/OFF on the operational control display panel
Transfer confirm	Users press ENTER (F4) to switch the load power interruption to the bypass based on prompts.
Transfer cancel	Users press CANCEL (F4) to cancel the load power interruption switch to the bypass based on prompts.
Manual turn on	Manually start the inverter by buttons on the display panel of operation panel.
Manual turn off	Manually shut down the inverter by buttons on the display panel of operation control.
Battery overtemp.	Battery over-temperature. Check the temperature of the battery and the ventilation.
Battery fault	The battery has already been aged (reserved).
Battery maintained	The battery test fails. And the battery needs to be switched.
Battery low pre-warning	This alarm message will be prompted before the final discharging voltage is reached. After the pre-alarm, the battery capacity allows a full load discharge of 3 minutes, which can be set by users, with a range of 3 to 60 minutes. Please shut down the load timely.
Battery end of discharge	When the cut-off discharge voltage is reached, the inverter will shut down. Check the AC outage status, and restore AC as soon as possible.
Inverter comm. fail	Communication between the internal monitor and the inverter fails.
Parallel comm. fail	Communication among the stand-alone inverters in the parallel system fails. First, check whether some of the UPSs in the parallel system are powered on. If not, power on these UPSs, and then check whether the alarm is cleared. Second, press the key of FAULT CLEAR.
Bypass unable to trace	<p>When the amplitude or frequency of the bypass voltage exceeds the normal range, the inverter software program will trigger this alarm. The set value of the amplitude is fixed at $\pm 10\%$ of the rated value. When the bypass voltage resumes normal, this alarm will be cleared automatically.</p> <p>First, check and ensure the bypass voltage and frequency shown on the operational control display panel are within the setting range. Caution that the rated voltage and frequency are dependent on the output voltage and output frequency respectively. Second, if the voltage is abnormal, measure the actual bypass voltage and frequency. If abnormality occurs, check the external power supply.</p>
Bypass abnormal	<p>When the amplitude or frequency of the bypass voltage exceeds the normal range, the inverter software program will trigger this alarm. The set value of the amplitude is fixed at $\pm 10\%$ of the rated value. When the bypass voltage resumes normal, this alarm will be cleared automatically.</p> <p>First, check whether there are such alarms as “bypass air switch closed” or “reversed phase of the bypass”. If so, clear these alarms first. Then check and ensure the bypass voltage and frequency shown on the display panel of operation control are within the setting range. Caution that the rated voltage and frequency are dependent on the setting level of the output voltage and that of the output frequency respectively. If the voltage is abnormal, measure the actual bypass voltage and frequency. If abnormality occurs, check the external bypass power supply. If this alarm message is sent frequently, the upper limit setting point of the bypass can be increased appropriately through the configuration software based on users' opinions.</p>

Alarm message	Annotation
Inverter asynchronous	When the phase angle of the inverter voltage differs from that of the bypass-phase voltage by more than 6°, the inverter software program will trigger this alarm. The set value of the amplitude is fixed at ±10% of the rated value. When alarm conditions are cleared, this alarm will be resumed automatically. First, check whether there are such alarms as “bypass over-tracing” or “bypass over-protection”. If so, clear these alarms first. Second, check whether the waveform of the bypass voltage is normal. If there is severe waveform distortion, users should confirm it and find a resolution.
Inverter output abnormal	The inverter output voltage exceeds the normal range, thus the load switched to the bypass.
Inverter overtemp.	Due to over-temperature of the inverter radiator, the inverter stops running. This alarm is triggered by signals of the thermostat for temperature monitoring, which is located at the inverter bridge radiator or the output transformer. After the over-temperature signal is cleared for 5 minutes, the UPS will recover automatically. If over temperature indeed exists, please check .First,whether the environment temperature is too high.Second, whether the air passage is blocked.Third whether the fan fails.Fourth,whether the inverter is overloaded overtime.
Fan fault	At least one cooling fan breaks down.
Inverter STS fail	At least one static switch at the inverter side is opened or shorts out. This fault will be locked until it powers off.
Bypass STS fail	At least one static switch at the bypass side is opened or shorts out. This fault will be locked until it powers off.
Operation invalid	When operational errors occur, this alarm message will be triggered.
Unit over load	This message will be sent when the load exceeds 105% of the rated value. Once the overload status is cleared, the alarm will be resumed automatically. First, find out which phase is overloaded referring to the load percentage displayed on LCD, in order to check whether the alarm is real. Second, if the alarm is real, measure the actual output current to ensure the validity of the display value. Then cut off the non-critical load. Severe imbalance of load in the parallel system may also lead to this alarm.
System over load	This message will be sent when the total load of the UPS parallel system exceeds 105% of the rated value. Once the overload status is cleared, the alarm will be resumed automatically. Find out which phase is overloaded referring to the load percentage displayed on LCD, in order to check whether the alarm is real. If the alarm is real, measure the actual output current to ensure the validity of the display value. Then cut off the non-critical load. Severe imbalance of load in the parallel system may also lead to this alarm.
Unit over load timeout	The UPS has been overloaded for a period longer than the allowable overload time. Note 1: the highest load phase displays the overtime overload in the first place; 2: when the load exceeds the rated value, “stand-alone overload” will be sent; 3: once it exceeds the allowable overload time, the static switch at the inverter side will be opened, with the load switching to the bypass. The inverter will restart one second after its shutdown. 4: 5 minutes after the load drops to 95% below, the system will switch to the inverter mode. Find out whether the alarm is real by referring to the load percentage displayed on LCD. If LCD displays overload, check the actual load to determine whether UPS is overloaded before the alarm is sent.
Byp. abnormal shutdown	Both the bypass voltage and the inverter voltage are abnormal, thus leading to load power interruption.
Inverter over current	Over-current of the inverter pulse width modulation (PWM) module.
Bypass phase reverse	Reversed phase of the bypass voltage. Normally, phase B lags behind phase A of 120°, while phase C behind phase B of 120°. Check whether the phase sequence of the UPS bypass power supply is right. If not, please correct it.
Load impact transfer	The system switches to bypass due to load shock. UPS can resume automatically. Start the load in sequence to lessen the load shock to the inverter.

Alarm message	Annotation
Transfer time-out	Since times of overload switch exceeds the setting value within the first one hour, the load remains to be powered by the bypass. UPS can resume automatically within one hour and switch to inverter-fed status.
Load sharing fault	The UPS stand-alone in the parallel system cannot equalize the load.
DC bus abnormal	Abnormity of the DC bus voltage leads to shutdown of the inverter, with the load switching to the bypass.
System transfer	All stand-alone in the parallel system switch to bypass-fed status simultaneously. LCDs of the UPS stand-alone which switch to bypass passively will display this alarm message.
Parallel board fault	The parallel panel fault may lead to system switch to bypass.
Parallel connect fault	Cables in the parallel system are connected incorrectly, or fail to form into a ring. Press the key of FAULT CLEAR to clear this fault, and then press the key of INVERTER ON to restart the inverter.
Bypass over current	The bypass current exceeds 135% of the rated value. UPS just sends a alarm , without any operations.
LBS Active	LBS settings come into effect, i.e. UPS runs as a LBS master or slaver in the double-bus configuration system.
LBS abnormal	UPS is set into LBS mode (master or slaver), but the LBS bus has no LBS signals. Check the wiring of LBS bus.
By. inductor overtemp.	The inductance temperature of the bypass equalized-flow is too high. Please check the environment and ventilation.
Static Sw. overtemp.	The temperature of the bypass or inverter output static switch is too high. Please check the environment and ventilation.
INV drive circuit fault	Drive cables of the inverter are disconnected, have poor contact, or are installed with incorrect model settings.
Bypass disconnect closed	The bypass switch is closed.
Bypass disconnect open	The bypass switch is opened.
Maint. disconnect closed	The maintenance bypass switch is closed.
Maint. disconnect open	The maintenance bypass switch is opened.
Output disconnect closed	The output switch is closed.
Output disconnect open	The output switch is opened.
Check UPS output	UPS is in shutdown mode, with output interrupted.
Output disabled	If UPS is not set to start automatically, it certainly will not start automatically when AC resumes after the shutdown caused by the end of battery discharge. And LCD will display this alarm message.
Normal mode	The UPS is in an AC inverter-fed mode.
Battery mode	The UPS is in a battery mode.
Source share mode	The UPS is in a joint inverter-fed mode.
Bypass mode	The UPS is in a bypass mode.

5. UPS Operation Instruction

This chapter details the UPS operational cautions and its daily operational methods.

5.1 Introduction

5.11 The Do's and Don'ts

 Important
Special attention: before the system powers on, commissioned engineers must remove the packing materials on top of the UPS.

 Important
Only after commissioned engineers have completed power-on starting and debugging for the first time can users conduct relevant operations. Components which can only be opened by tools behind the protection cover plate are non-operable for users. Only certified maintenance personnel are allowed to open such cover plates. The UPS AC input and output terminals are of dangerous voltage anytime.

1. For displays and buttons on the display panel of operation control mentioned in all the steps as well as the power supply switch, refer to *Chapter 4 Operational Control Display Panel*.
2. During the operation of running mode switch, buzzer warning rings. Press the key of SILENCE ON/OFF for mute function.
3. When UPS adopts the traditional lead-acid water-injected battery, the system offers automatic equalizing charge. Under such circumstance, in case of power restoration after AC power interruption for a long time, the charging voltage of the battery will be higher than normal, and will resume normal after charging for several hours. This is a normal phenomenon.

5.2 UPS Start-up Procedure (Entering the Inverter Power Supply Mode)

This procedure should be followed to start the UPS when it fully powers off, i.e. UPS has not supplied power to the load directly or through the maintenance bypass switch before. Here we assume that the UPS installation has been completed; it has been debugged by engineers; while the external power supply switch is closed.

 Alarm—UPS output terminal with AC voltage
This procedure will lead to the presence of AC voltage at the UPS output terminal. If necessary, please open the connection switch of the subordinate load, and attach an alarm label to the load connection.

1. Open the UPS front door, and find the power supply switch.
2. Close bypass switch Q2 and UPS output switch Q5. And close all external output disconnectors (if any). At this moment, LCD displays “start running”. After the UPS starts, it will firstly be in the bypass-fed status. Status of LED indicators for the moment can be seen in Table 5-1.

Table 5-1 Status of LED indicators

LED indicator	Status
Bypass indicator	Green light keeps on.
Load indicator	Green light keeps on.
Battery indicator	Red light keeps on.
Alarm indicator	Yellow light keeps on.

3. Close input switch Q1.

The rectifier starts, with its indicator flickering in green. After about 15 seconds, the rectifier begins to run normally, and its indicator turns into green and keeps on.

4. Make sure the bus voltage is normal, and the battery polarity is proper. Then close the external battery switch located in the battery switch box.

5. When system detects the battery, the red battery indicator will light off.

6. Open (or check to open) the internal maintenance bypass switch Q3.

7. Press the button of INVERTER ON for 2 seconds.

The inverter begins to start. When voltage frequency of the inverter synchronizes with that of the bypass, the inverter indicator will flicker. After the inverter starts, UPS will switch to an inverter-fed status from the bypass-fed status. At that moment, the bypass indicator will light off, while the inverter one will keep on in green.

8. Check and ensure that no alarm messages pop up in the upper right corner of the LCD display screen. LED status can be seen in Table 5-2.

Table 5-2 LED indicator status

LED indicator	Status
Rectifier indicator	Green light keeps on.
Bypass indicator	Light off.
Battery indicator	Light off.
Inverter indicator	Green light keeps on.
Load indicator	Green light keeps on.
Alarm indicator	Light off.

UPS runs in the inverter power supply mode

5.3 UPS Start Procedure (Entering the Economic Mode)

This procedure can only be applied to debug the stand-alone system already set in economic mode (ECO) by engineers.

After the procedure described in 5.2 *UPS Start Procedure (Entering the Inverter Power Supply Mode)* are completed, ensure that the bypass indicator on the operational control display panel keeps on in green (indicating that the load is fed by bypass AC power).

UPS runs in the economic mode

5.4 Battery Test Procedure

In the battery test, the UPS system will switch to a jointly-fed mode, i.e. 15% of the load is fed by the battery, while the left by AC input power.

Types and pre-conditions of the battery test

1. Two types of battery test for choice

- Battery maintenance test: check the battery status, and conduct a 20% discharge of the battery.
- Battery capacity test: to precisely measure the battery capacity, conduct a full discharge of the battery (until the alarm of low battery voltage occurs).

2. Operators can conduct battery tests when the following two conditions are met:

- The load must be between 20% and 80% of the UPS rated capacity.
- The battery has just completed a float charge for more than 5 hours.

The battery test is conducted via the LCD menu on the display panel of operation control, and needs to succeed with the password authentication. In case of battery or AC failure, the battery test will automatically stop at once. The UPS load will be fed by AC power or the battery alone without any load power interruption.

Battery procedure

1. Select the “Test Command” menu on LCD of the UPS display panel of operation control. Use LeftShift or RightShift to enter the “Test Command” menu.

2. Select the desirable test (“Battery maintenance test” or “Battery capacity test”).

Move the cursor to the desirable test item by use of WindowSwitch (F1), PageUp (F2) and PageDown (F3), and press Enter (F4) to confirm.

Use PageUp (F2) and RightShift (F3) to enter the password following the prompts on the screen. Press Enter (F4) to confirm.

3. Wait for completion of the battery test.

When the test is done, the system will update the battery data automatically, including its backup time and aging coefficient. The backup time refers to the battery-fed discharge time, while the aging coefficient indicates the capacity loss severity during its use.

4. Stop the battery test.

The battery test can be stopped halfway by selecting the “Stop testing” item under the “Test Command” menu.

5.5 UPS Self-detection Procedure

UPS self-detection includes detection of its control function, LED prompts of the UPS display panel and the audible alarms. It is conducted via the menu, and needs to succeed with the password authentication. The whole process takes 5 seconds. Operators can start it through the display panel of operation control.

The UPS self-detection procedure is listed below:

1. Select the “Test Command” menu on LCD of the UPS operational control display panel. Use LeftShift or RightShift to enter the “Test Command” menu.

2. Select the “System test” item.

Move the cursor to the desirable test item by use of WindowSwitch (F1), PageUp (F2) and PageDown (F3), and press Enter (F4) to confirm.

Use PageUp (F2) and RightShift (F3) to enter the password following the prompts on screen. Press Enter (F4) to confirm.

3. Wait for completion of the UPS self-detection.

After 5 seconds, the self-detection result will be shown on screen: rectifier, inverter or display unit normal or with fault.

4. Stop the UPS self-detection.

The UPS self-detection can be stopped halfway by selecting the “Stop testing” item under the “Test Command” menu.

5.6 Maintenance Bypass Operation Procedure (UPS Shutdown Procedure)

The following procedure will switch the load from the UPS-fed protection status to the one that directly connected to bypass input through the maintenance bypass switch.



Caution—Danger of load power interruption

Except emergencies, before your operation, please ensure that no alarm prompts pop up in the upper right corner of the UPS display screen to avoid load power interruption. If there are alarms, prompts will pop up on the screen for operators to confirm or cancel the operational step which may lead to load power interruption, before it is taken.

1. Press the button of INVERTER OFF on the UPS display panel.

With the inverter shut down, the load is fed by the UPS through the static bypass. At the moment, the inverter indicator lights off, while the alarm indicator lights on.

2. Close the internal maintenance bypass switch Q3.

At the moment, the maintenance bypass power supply is in parallel with the UPS static bypass power supply. Relevant executed operations will be shown on the display window, maintenance bypass closed for instance.

3. Open the output switch Q5.

At the moment, the switch from the UPS to the bypass circuit is done and the loads are directly powered by the bypass circuit.



At the moment, the load device is not under the AC power supply abnormality protection.

To shut down the rectifier and the battery, please continue the following steps.

4. Press the EPO button on the UPS front door for 2 seconds.

It will shut down the rectifier and the inverter, the static switch and the battery disconnected, but will not affect the manual maintenance bypass switch.



Before this step, please ensure the EPO contact does not connect to the external switch or device.

5. Open the input switch Q1 and bypass switch Q2.

6. Open the external battery switch located in the battery switch box.

As all internal power supplies fed by AC power are shut down, all LED indicators on the display panel will light off with LCD displaying shutdown.

At the moment, the load is powered by the maintenance bypass as the UPS shuts down entirely.

5.7 Shut-down Procedure (Complete Shut-down of the UPS and Loads)

Follow the procedure to entirely shut down the UPS and cut off the load power supply. Open all power supply switches and breakers so that UPS can no longer supply power to the loads.



The following procedure will cut off the load power supply.

1. Press the EPO button on the UPS front door. It will get the rectifier and the inverter shut down, the static switch and the battery disconnected, thus cutting off the load power.

Note: Except in case of emergencies, please don't press the EPO button.

2. Open the door of UPS, and find the power supply switch.

3. Open the input switch Q1.

4. Open the external battery switch located in the battery switch box.

5. Open the output switch Q5.

6. Open the bypass switch Q2.

7. Ensure that the maintenance bypass switch Q3 is opened.

With all AC-fed internal power supplies shut down, all LED indicators on the display panel will light off, with LCD displaying shutdown.

8. To completely remove power from the UPS, its external AC distribution switch (in split bypass system, the rectifier and the bypass both use an independent power input, therefore there are two switches) and the external output switch must be opened, with an alarm sign affixed.

5.8 Emergency Shutdown (EPO) Procedure

At the UPS front door, an emergency power-off (EPO) button is provided to shut down the UPS in case of emergency (e.g. fire, flood etc.). To conduct an emergency power-off, just press the EPO button for 2 seconds. The

system will then shut down the rectifier and the inverter, and rapidly cut off the load power (including the inverter and the bypass output), while the battery will stop charging or discharging.

If the UPS still gets AC input, its control circuit is still live, but the UPS output has been shut down. To completely cut off the UPS AC power supply, open its external AC input switch.

5.9 UPS Reset Procedure

In case the UPS shuts down due to the use of EPO, or inverter over-temperature, overload shutdown, battery over-voltage, too frequent switch etc., follow the reset procedure below to make the UPS resume to its normal working status after the fault is cleared following the alarm prompts on the display screen.

When users can ensure that the fault is cleared with no remote EPO signals:

1. Press the key of FAULT CLEAR to get the system out of emergency shutdown status.

 Attention
The rectifier restarts. And the load is powered by the bypass. When the rectifier starts, its indicator will flicker. When it begins to run in normal status (about 15 seconds later), its indicator will keep on in green.

2. Press the key of INVERTER ON at the right side of the display panel for more than 2 seconds.

 Attention
5 minutes after the over-temperature signal disappears, once the over-temperature fault is cleared, the rectifier will start automatically.

When the EPO button is pressed, the UPS will shut down completely if its AC input has been cut off. When AC input resumes, for instance, if you close the bypass input power supply switch (Q2) and the UPS output power supply switch (Q5), the UPS will start and enter the bypass mode, while the output will resume.

 WARNING
The UPS has output, if the internal maintenance bypass switch Q3 is closed, while the UPS has AC input.

5.10 Automatic Start

In case of AC power outage, the UPS supplies power to the loads through the battery system, and stops outputting until the battery reaches the end of discharge (EOD) voltage.

The UPS will restart automatically and resume output power, when the following conditions are met:

- AC power has resumed.
- The automatic start function of the UPS is set up.
- The automatic start-up delay (with a default setting of 10 minutes) is done. During the process of the automatic start-up delay, the battery is charged to avoid power interruption to the load devices in case of another AC power outage.
- If the automatic start function of the UPS is not set up, users can press the button of FAULT CLEAR to manually start the UPS.

5.11 Language Selection

The LCD menu and data can be displayed in two languages, Chinese and English.

Take the following steps to select a desirable language.

1. Under the main menu, press F1 (WindowSwitch) to move the cursor to the first line on the screen.
2. Press F2 and F3 (LeftShift and RightShift) to select the "Menu Language".
3. Press F1 (WindowSwitch) to move the cursor to the UPS data window on the screen.

4. Press F2 and F3 (PageUp and PageDown) to select a desirable language.
5. Press F4 (Enter) to confirm.
6. Press F1 (ESC) repeatedly to return to the main menu. At the moment, all information on LCD will be displayed in the selected language.

5.12 Alteration of the Current Date and Time

To alter the system date and time, take the following steps:

1. Under the main menu, press F1 (WindowSwitch) to move the cursor to the first line on the screen.
2. Press F2 and F3 (LeftShift and RightShift) to select the "Function Set" menu.
3. Press F1 (WindowSwitch) to move the cursor to the UPS data window on the screen.
4. Press F2 and F3 (PageUp and PageDown) to select the "date and time" item, and then press F4 (Enter) to confirm.
5. Move the cursor to the date and time display line, and press F4 (Enter) to confirm.
6. Use F2 and F3 (PageUp and PageDown) to enter the current date and time.
7. Press F4 (Enter) to confirm. And press F1 (ESC) to return to the main menu.

6. Battery

This chapter introduces the battery. The content includes battery safety, information on battery installation and maintenance, the protective function of the battery, and the connection of battery circuit breaker box and battery temperature transmitter options.

6.1 Introduction

The UPS battery bank, which consists of battery blocks connected in series, provides rated DC string voltage for the UPS converter. The backup time (the time which the battery can supply power to the load in the event of a DC interruption) is limited by the ampere hour capacity of the battery blocks, thus in some cases several strings should be connected in parallel.

For better installation, the batteries are contained in a specially-designed battery cabinet or battery rack.

In the time of maintenance or repair, the battery bank must be disconnected from the UPS. This operation can be done via a battery switch with proper capacity. The switch must stay very close to the battery terminal, and the power and control cables must be connected to the UPS using the most direct route possible.

If the battery blocks are connected in parallel in order to extend the backup time, a cutting device must be equipped accordingly. Each of the paralleled strings should be fitted with an isolating device so that maintenance can be done for one battery set while the others remain in service.

6.2 Safety

Special attention should be paid when working with the batteries of the UPS System. The full nominal voltage can reach 480Vdc when all the batteries are connected, which is extremely hazardous. Please follow the code for safety operation under high voltage. Only qualified personnel are authorized to install the battery and conduct maintenance. In terms of safety, the battery installation must be segregated from all but qualified personnel by locating the batteries in a lockable cabinet or in a specially-designed battery room.



1. The battery must be firmly connected. The connection between all the terminals and batteries needs to be verified, so as to meet the requirements in the instructions or user's manual. All the terminals and battery connection should be re-tightened at least once a year; otherwise it may incur fire!
2. When you receive the battery and before you use it, please check its external condition. If the wrapping is broken, the terminal of the battery is contained, corroded or rusted, or the external shell is cracked, distorted or leaking, the battery should be replaced by a new one, in case of causing low capacity, electric leakage and even fire disaster.
3. Since the battery is very heavy, please move and lift the battery appropriately to prevent personal injury or damage with the battery terminal which could lead to fire.
4. The terminal of the battery cannot withstand any external force, such as the pulling or twisting by the cable from outside, which could damage the interior connection and therefore lead to fire.
5. battery needs to be installed and stored in a clean, cool and dry environment. Please do not install it in a sealed battery compartment or a closed room. The ventilation in the battery compartment should at least meet EN50272-2001; otherwise it may result in battery expansion, fire and even personal injury.
6. The battery must be installed away from the transformer. It must be kept away from ignition source when in use. Do not burn or heat the battery in the fire; otherwise it may cause leakage, bulging, fire and even explosion.
7. Please do not connect the positive and negative terminal with any conductor. Remove your ring, watch, necklace, bracelet and other metal objects when operating on the battery. Make sure the tools being used, such as wrenches, are insulated; otherwise the battery may catch fire, which could result in casualties and explosion.



8. Please do not attempt to disassemble, remodel or damage the battery; otherwise it may occur short circuit, leakage and even injuries to human body.
9. To clean the shell of the battery, please use damp cloth rather than dry cloth or duster so as to avoid static or sparkles. Avoid using organic solvents such as thinner, gasoline and benzene. The substances may cause cracks on the battery container and even occur fire.
10. Under normal conditions, the sulfuric acid is absorbed to the internal separator and electrode plate in the battery. But in case of damage with the battery, the acid would leak. Therefore, wear rubber gloves, protective glasses, and a rubber apron when operating on the batteries to prevent the sulfuric acid from harming your eyes and skin.
11. By the end of its service life, malfunctions such as short circuit, low electrolyte level and erosion of positive grid would possibly occur. Under such conditions, further use of the battery could trigger thermal runaway, bulging and leakage. Therefore, please replace the battery in time.

6.3 UPS Battery

UPS battery generally adopts valve regulation. Currently, "valve-regulated" battery refers to the previous "sealed" and "maintenance free" battery.

Valve regulated battery is not totally sealed. Particularly when overcharged, some air is discharged, the amount of which is less than that of water battery. As for the battery installation and design, enough space should be reserved to ensure good ventilation.

Similarly, valve regulated battery is not really maintenance free. Keep the battery clean, and conduct a regular check of whether the battery connection is under good condition and without corrosion. For the detailed information, please refer to the battery maintenance.

The battery should include no more than four sets of batteries connected in parallel. A mix usage of batteries with different types, brands and conditions is not allowed. Otherwise, the inconsistency may cause over-discharge and under-charge for some of the batteries, which will stop working in advance, causing the overall insufficient power supply of the entire battery set.

The battery must be stored when fully charged. During the transit or storage, the battery will lose part of its capacity due to self-discharge. Therefore, please recharge before usage. For storage, please notice that the ambient temperature should stay from -15°C to $+45^{\circ}\text{C}$, ideally from 20°C to 25°C . The battery needs to be recharged every three months to supplement the lost electricity caused by self-discharge. But it may differ among different types of batteries. For specific operations, please follow the guide of the battery manufacturer.

It is crucial to fully charge the battery before testing its backup time. The test might last several days, and hence it should only be conducted after an uninterrupted float charge which lasts for at least one week.

The performance of the battery will be improved after weeks of operation or two to three cycles of charge and discharge.

To avoid overcharge and undercharge, please set the battery management parameters according to the floating charge voltage and temperature compensation coefficient required in the materials provided by the battery manufacturer. When the discharge ends, please start charging the battery quickly.

6.4 Installation and Design Notice



Safety instructions concerning the use and maintenance of UPS batteries are provided in the related battery manufacturers manuals. The battery safety information contained in this section relates to key considerations which must be taken into account during the installation design process and may affect the design outcome depending on local conditions.

6.5 Installation Environment and Number of Batteries to be Installed

6.5.1 Installation Environment

6.5.1.1 Ventilation Quantity for Fresh Air (EN50272-2001)

When the battery is under operation, the air flow rate for ventilation must be guaranteed in line with the following formula:

$$Q = 0.05 \times n \times I_{gas} \times C_{rt} \times 10^{-3} \text{ [m}^3\text{/h]}$$

Where

Q—air flow rate per hour, m³/h

N—number of batteries

I_{gas}—the gassing current density under float charging or equalized charging, measured by mA/Ah

I_{gas}=1, 2.27V/ unit float charge

I_{gas}= 8, 2.35V/ unit equalized charge

C_{rt}—20hr battery rated capacity

6.5.1.2 Temperature

Table 6-1 Environment Temperature Range

Category	Temperature	Notes
Recommended Temperature	20°C ~ 25°C	The environment temperature under which the battery operates should neither be too high nor too low.
Temperature for Temporary Operation	-15°C ~ 45°C	If the average external temperature in which the battery operates increases from 25°C to 35°C, the service life of the battery would decrease by 50%; if the operation temperature is above 40 °C, the service life would decrease exponentially.

The higher the temperature is, the shorter the service life for the battery becomes. Under the low temperature, the charge-discharge performance of the battery would be largely reduced.

The battery must be installed in cool and dry environment to avoid heat and sunlight, with a humidity rate under 90%.

Environment temperature, ventilation, space, floating charge voltage and ripple current all have an influence on the temperature of battery. Uneven temperature of the battery set will lead to uneven voltage, which may produce problems. Therefore, an even temperature is extremely important. The inter-layer temperature difference should be controlled within 3°C. The valve regulated battery is very sensitive to temperature. Therefore it should be operated under the temperature between 15°C ~ 25°C. When the battery cabinet is mounted near the UPS unit, it is the battery—not the UPS—which dictates the designed maximum ambient temperature. For instance, in the case of “valve-regulated” batteries, the ambient room temperature should be kept between 15°C and 25°C, and *not* between 0°C and 40°C (which is the specified main equipment operating temperature range). Temperature excursions are permissible for short periods of time provided the average temperature does not exceed 25°C.

6.5.2 Number of Batteries

The voltage of float charge is generally set at 432 Vdc to ensure the float charge voltage for a single battery is 2.25V. The cut-off voltage of discharge is set to be 320 Vdc to ensure the voltage for a single battery is 1.67V. Please refer to the Table 6-2.

Table 6-2 Number of Batteries

Type	10~120KVA
number of Batteries (standard)	192
Cut-off voltage of discharge	320V

float charge voltage	432V
equalized charge voltage	451V

6.6 Connecting the Battery

6.6.1 Battery Assembling

1. Before the installation, please check that the battery does not have any external damage and whether the fittings are enough or not, and read through this user's manual, as well as the manual or instruction provided by the battery manufacturer.
2. A minimum space of 10 mm must be left on all vertical sides of the battery blocks to allow free ventilation.
3. Certain space should be left between the battery top and the upper shelf in order to facilitate monitoring and repair.
4. The battery installation should be done from the bottom of the shelf, and then moving upwards, to prevent raising the center gravity. Install the battery properly to avoid vibration and shocks.

6.6.2 Battery Wiring

1. All the battery cabinets or shelves must be well connected and grounded.
2. When using more than one set of battery, first connect the batteries in series, and then arrange the batteries in parallel. After verifying that the total voltage for battery blocks is correct, you can load and power on. Connect the anode and cathode of the battery with the UPS according to the signs marked on the equipment carefully. If the terminals are not connected correctly, it could incur explosion, fire and damage to the battery and the UPS. It could even cause personal injury.
3. An insulating cover should be installed to each terminal after the connection.
4. When connecting the cables between the batteries and the circuit breaker, always connect the circuit breaker first.
5. The bending radius of the cable should be longer than 10D (D refers to the external diameter).
6. Do not pull the battery cable as well as the terminals after they are connected.
7. Do not cross or tie up the cables when connecting the terminals

6.7 Battery Installation

Whatever battery mounting system is used, pay attention to the following conditions:

① Battery configuration

Whatever battery mounting system is used, the principle for battery layout is that it is not allowed to contact any two electric bare metal parts, of which the potential voltage is over 150V. If such condition is unavoidable, insulated terminal shields and insulated cables must be used.

② Service Platform

The service platform (or duck-board) must be slip-proof and insulated, with a width of at least one meter.

③ Wiring

All wiring must be as short as possible.

6.8 Battery Maintenance

For battery maintenance and related dos and don'ts, please follow IEE-Std-1-188-2005 and the user's manual provided by the battery manufacturer.



Check if the screws at the interconnecting pieces are well tightened. If the connection becomes loose, screw it up.

Test and make sure that all the safety equipment being used function properly, especially that the battery management parameters are set within normal spectrum.

Measure and record the temperature in the battery room.

Check whether the battery terminals are broken or over-heated and whether the shields or caps are damaged.

6.9 Battery Recycle

In case of battery leakage or damage, place it in an anti-acid container and then dispose the battery in accordance with local regulations.

Waste lead-acid battery is a dangerous waste strictly controlled in China in terms of waste battery pollution. Batteries must always be stored, transported, used and disposed of according to local environmental laws.

According to the regulations, waste lead-acid battery should be recycled, and any other way of disposal is forbidden. Littering waste lead-acid battery, as well as other improper ways of disposal would cause serious pollution to the environment and would be subject to legal liability.

7. Parallel System

This chapter introduces the installation and operation procedures of the UPS “1+N” parallel system.

7.1 Introduction

The UPS parallel system allows at most six standalone UPS machines of the same type and capacity to operate in parallel, without the help of a unified static bypass circuit. When the system switches to the bypass power supply, the load is equally shared by the bypass static switches.

From the perspective of power, the configuration of the standalone UPS machine is the same with the ordinary standalone machine. The parallel system manages the current sharing, synchronization and bypass switches via the control signals. The control signals are connected with the parallel-connected control cables, which are consisted of multi-core cables, connecting all the standalone machines of the system and are connected in a ring.

When the parallel system includes three or more stand-alone machines, the bypass current sharing inductors are recommended to be connected to the static bypass in series.

7.2 Installation of the “1+N” Parallel System

The basic installation procedure for the parallel UPS system is similar to that of the standalone UPS machine. This section only introduces the differences between these two modes. The installation of a parallel UPS configuration must follow the installation procedure for standalone UPS machines as well as the requirements detailed in this chapter.

7.2.1 Initial Check

Choose appropriate options and ensure that all the stand-alone machines are of the same capacity and type, with compatible software and firmware.



In order to ensure that all the stand-alone machines can operate in a coordinated manner in the “1+N” parallel mode, each one needs to be set up independently through the backstage setting software. The setup must be accomplished by professional maintenance staff.

7.2.2 Cabinet Installation

Place the stand-alone UPS machines side by side and connect them according to Figure 7-1.

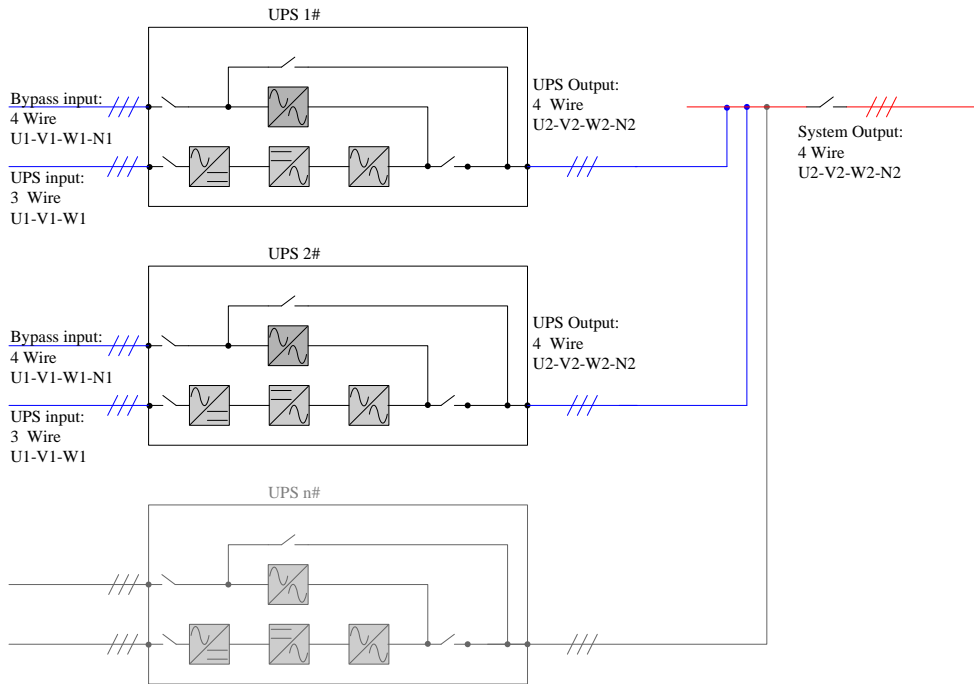

Figure 7-1 functional block diagram for the “1+N” parallel system

7.2.3 Protector

Please refer to the instructions in *3.1.6 Protector*

Note: If any residual current detector (RCD) is used at the UPS input supply, only one public protector is needed to be installed at the bypass DC supply.

7.2.4 Power Cables

Please refer to *3.1 Wiring for Power Cables*

Note: The length and specification of the power cables (including the bypass input cables and UPS output cables) should be the same. So the load will be shared equally among each unit of the parallel system even when on bypass mode.

7.2.5 Control Cables

7.2.5.1 Parallel Cables

Shielded and double insulated parallel cables which are 20 meters in length are offered. The cables must be connected in a ring configuration between all the UPS stand-alone machines, as shown below. The specific procedure is as follows: connect X1-1 and X2-2 on the parallel board of the first stand-alone UPS machine to the X1-2 and X2-1 of the next parallel board respectively. Do the same with the following machines.

Parallel board is installed is mounted on the inside door of each UPS stand-alone machine. The ring configuration ensures highly reliable control. Refer to Figure 7-2.

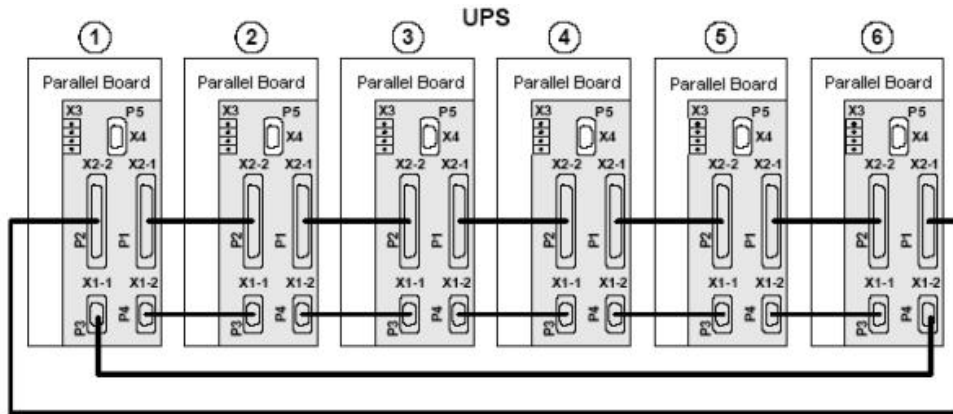

Figure 7-2 Connection of parallel control cables for the “1+N” system

7.2.5.2 Emergency Shutdown (EPO) Parallel Board

The installation procedure is the same with that of the stand-alone system. Refer to the section of *Emergency Power-off Input Port (X2)* of 3.3.1 *Monitor Board Port*

7.2.5.3 Battery Control

The installation procedure is the same with that for the stand-alone machine. Refer to 3.3.2 *Battery Control*.

7.2.5.4 External Bypass and Output Interlock

EXT-Maint (X3-1&2) on the UPS parallel board M3 provides external maintenance bypass interlock protection for the UPS. When there is open circuit, the switch is off; when there is short circuit, the switch is on.

EXT-Out (X3-3&4) on the UPS parallel board provides external output interlock protection for the UPS parallel system. When there is short connection, the switch is off; when there is short circuit, the switch is on.



Attention

UPS Parallel Board M3 is located behind the protection cover plate at the inside door. It can only be opened by maintenance staff with special tools. To ensure the operation of X3: 3&4, the jumper JP1 should be removed (near X3).

7.3 Operation Procedure for “1+N” Parallel System



WARNING

If the residual current detector (RCD) is used for the UPS input supply, public devices could be connected only at the bypass input.

At the time of electrical connection, currents will not get separated promptly, which may result in RCCB trip one after another.



Take one step at a time—perform each step in every stand-alone UPS machine before proceeding to the next step.

7.3.1 Start-Up Procedure (Entering the Inverter Power Supply Mode)

This procedure is applicable when the UPS is completely out of power, i.e. the UPS has not supplied power to the loads or supplied power through the maintenance bypass circuit. It is assumed that the installation is complete, the system has been commissioned by authorized personnel and the external power switches are closed.

For operating procedure, refer to 5.2 *UPS Start-up Procedure (Entering the Inverter Power Supply Mode)*.

7.3.2 Operation Procedure for the Maintenance Bypass (UPS shut down)



  WARNING
<p>The internal maintenance bypass should not be used if the parallel system consists of two or more UPS stand-alone machines.</p>

For operating procedure, refer to 5.6 Maintenance Bypass Operation Procedure (UPS Shutdown Procedure)

7.3.3 Shut Down and Isolate One of the UPS Machines in the Parallel System

1. Switch off Q5 (output switch), Q1 (input switch) and Q2 (bypass switch) in turn.
2. Switch off the battery switch in the battery cabinet.

To completely isolate the UPS, the AC power input switch (the rectifier and/or bypass power input) and external output switch at the power distribution cabinet must be opened. If the power distribution cabinet is not equipped with independent UPS output disconnecter (and its auxiliary contacts), pay attention that the voltage of other operating UPS still exists on the output terminals of the powered-off UPS.

  Warning
<p>If the power distribution cabinet is not equipped with independent UPS output disconnecter (and its auxiliary contacts), please notice that the voltage of other operating UPS is still existing on the output terminals of the shut-down UPS.</p> <p>Warning: Wait for around five minutes to let the voltage of DC bus capacitor discharged.</p>

7.3.4 Resume the Isolated Stand-alone Machine in the Parallel System

This procedure is used for re-integrating a UPS stand-alone machine that has been previously isolated from the parallel system. It is assumed that the installation is completed, the system has been commissioned by authorized personnel and the external power switches are closed.

1. Open the UPS door and the power switches can be seen.
2. Cut off (or confirm whether it is cut off) maintenance bypass power switch Q3.
3. Close the input bypass power switch Q2 and the UPS output power switch Q5. (Close the external output switch if there is one). The LCD display becomes active.
4. Close the Input Power Switch Q1.

When the rectifier starts, the indicator on the UPS operation control panel flickers, which lasts for about 15 seconds. After that, the light turns green.

5. Close the external battery switch which is located inside the battery cabinet or near the battery rack.
6. When the system detects the battery, the battery charger starts working and the red indicator is off.
7. Press INVERTER ON button for two seconds.

The inverter will start up and the inverter indicator flashes in case it synchronizes to the load voltage frequency. After the inverter is ready, the UPS connects to the load, the inverter indicator becomes steady green and the output indicator turns green.

8. Check that no "Warning" message is displayed at the top right corner of the LCD Monitor and the status of the LED indicator is shown as the Table 7-1.

Table 7-1 LED indicator

LED	Status
Rectifier indicator	green
Bypass indicator	off
Battery indicator	off
Inverter indicator	green

LED	Status
Load indicator	green
Alarm indicator	off

7.3.5 Shut-down Procedure (Complete Shut-down of the UPS and Loads)

For detailed operation procedure, please refer to 5.7 *Shut-down Procedure (Complete Shut-down of the UPS and Loads)*

7.4 Dual Bus System (Optional)

7.4.1 Cabinet Installation

As is shown in Figure 7-3, the dual bus system consists of two independent UPS systems; each consists of one or more parallel single UPS units. With its high reliability, the dual bus system can be used loads with multiple input terminals. For single input loads, a static transfer switch (STS) can be added to supply the load as an optional part. The module synchronizes the output of two independent (or parallel) UPS systems through a Load Bus Synchronizer (LBS). One system is designated as the master, and the other is designated as the slave. The operation modes covered comprise master and/or slave operating inverter or bypass mode.

Place the UPS units side by side and follow the below instructions to connect the units.

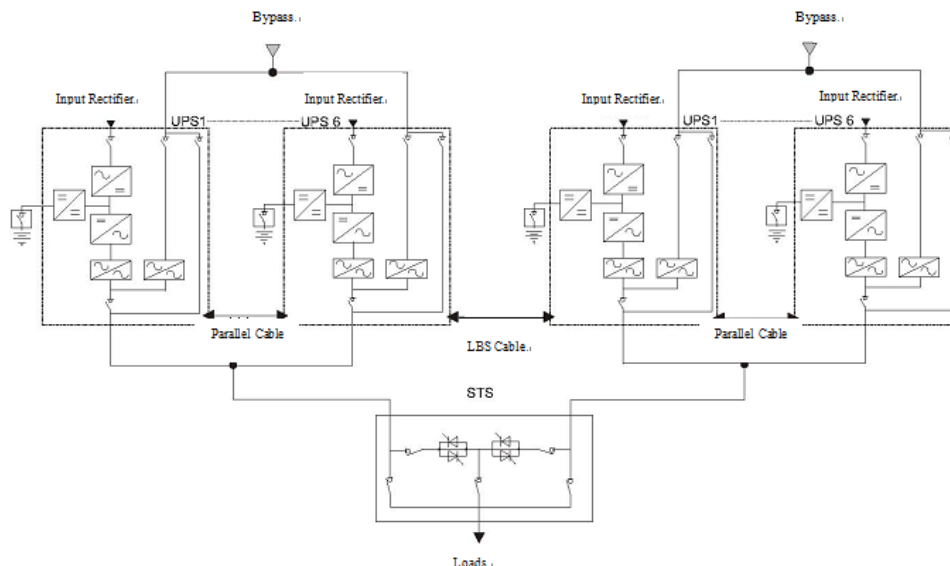

Figure 7-3 Typical Dual Bus System Configuration (using STS and LBS cables)

7.4.2 Protector

Refer to instructions in 3.1.6 *Protector*

7.4.3 Power Cable

The wiring of power cables is similar to that of standalone UPS system. Please refer to 3.1 *Wiring of Power Cables*

The bypass and main input sources must be referenced to the same neutral potential. If the input leakage current protector is installed, then it must be located in the upstream of the common neutral sinking point.

7.4.4 Control Wire

Connecting the Dual Bus System with Two Stand-alone Machines

If the system consists of two single stand-alone machines, connect the LBS ports (X4 on parallel board) of the machines with 9pin LBS cables (optional). Also use the LBS cables to connect any two of the 25-core terminals (X2-1 or X2-2) on the two machines, as shown in Figure 7-4.



WARNING

Though the LBS cables specialized for 25 cores look the same with parallel cables from appearance, they are not parallel cables and cannot be replaced by parallel cables. Otherwise operation disorder would occur in the UPS system.

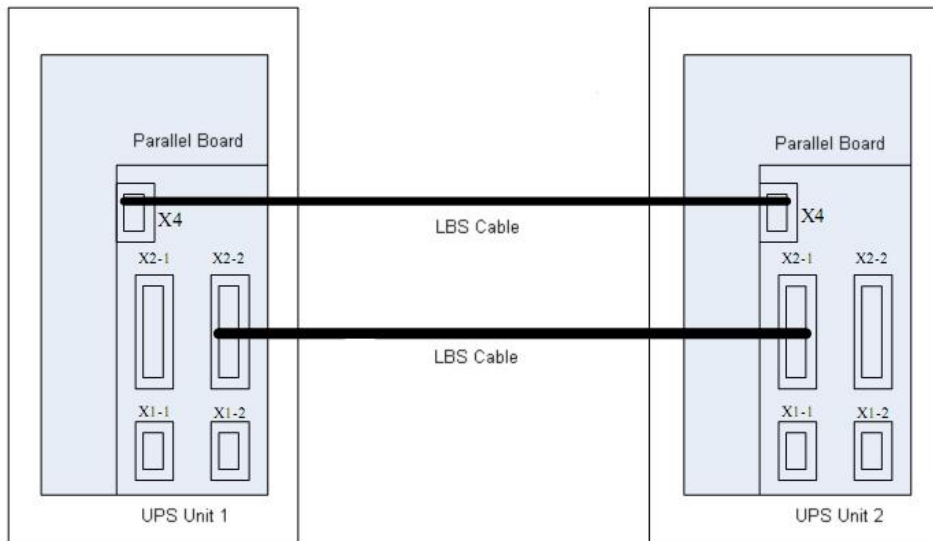

Figure 7-4 Connection of Dual Bus System with Two Machines (with LBS Cables)

Connecting the dual bus system with a stand-alone machine and a parallel system

If the dual bus system includes a stand-alone UPS machine and a parallel system, follow Figure 7-5 to connect the system. Connect the LBS port (X4 on the parallel board) on the stand-alone UPS machine with the LBS port on any one of the UPS machines in the parallel system, using LBS cable with 9 cores. Use the LBS to connect any one of the ports with 25 cores (X2-1 or X2-2) on the stand-alone UPS machine with any one of the LBS ports in the parallel system. Pay attention that one end of the LBS cable has 9 cores, while the other has 25 cores, which should be connected to X4 of the parallel system and the 25-core port of the single UPS respectively.

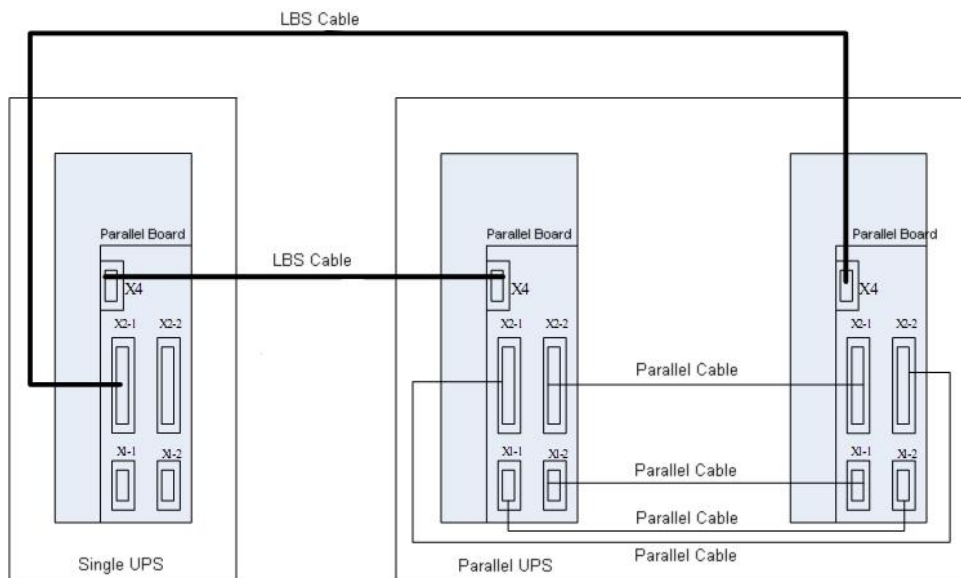

Figure 7-5 Connection of the Dual Bus System with a Stand-alone and a Parallel System (with LBS Cables)

Connecting the Dual Bus System with Two Parallel Systems

For the dual bus system with two or more parallel system, it must be connected by LBS cables (optional) in a ring. The interface box is the X4 on the parallel box, as illustrated by Figure 7-6.

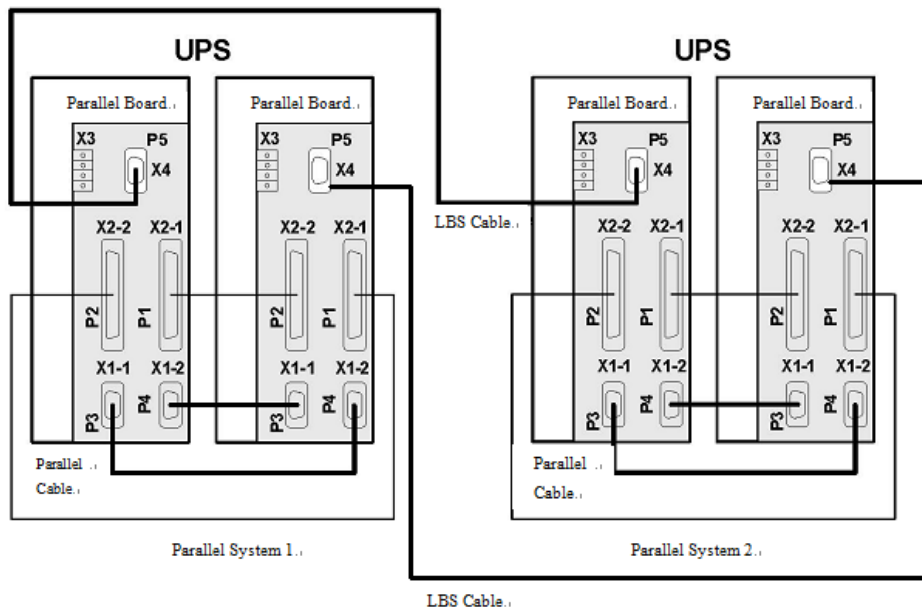

Figure 7-6 Connection of the Dual Bus System with Two Parallel Systems (Using LBS Cables)

8. Product Specification

This chapter provides the UPS product specification.

8.1 Compliance and Standards

Table 8-1 Compliance and Standards

Item	Year	Standard
Safety Requirement	2017	IEC62040-1
EMC	2016	IEC62040-2
Method for Designing and Testing	2011	IEC62040-3

8.2 Environment Condition

Table 8-2 Environment Condition

Item	Unit	Rated Power (kVA)								
		10	15	20	30	40	60	80	100	120
Operating Temperature	°C	0~40								
Highest temperature for working 8 hours per day	°C	40°C de-rate power by 1.5% for every 1°C increase between 40 °C to 50°C								
Highest temperature for working 24 hours per day	°C	Up to 35								
Relative Humidity	-	When 20°C, ≤95%								
Altitude	m	≤1000m a.s.l. de-rate power by 1% per 100m between 1000 and 2000 m								
Storage/Transport Temperature	°C	-25~70								

8.3 Mechanical Characteristics

Table 8-3 Mechanical Characteristics

Item	Unit	Rated Power (kVA)									
		10	15	20	30	40	60	80	100	120	
Height	mm	1050			1100			1400		1600	
Width	mm	350			430			720		890	
Depth	mm	650			830			690		775	
Net ¹	kg	148	163	163	230	255	386	426	625	685	
Mass ¹	kg	168	183	183	263	288	432	472	695	755	
Ventilation	-	By internal turbines									
Wiring Method	-	Through the bottom of machine									

Note:

1. As the materials used by different manufacturers are different in weight, the net weight and gross weight of the UPS offered above are only for reference. Detailed information is in accordance with the final product.

8.4 UPS Electrical Characteristics (Rectifier Input)

Table 8-4 Electrical Characteristics (Rectifier Input)

Item	Unit	Rated Power (kVA)								
		10	15	20	30	40	60	80	100	120
Rated AC Input Voltage	Vac	380/400/415 V								
Type of Input Power	-	three-phase without neutral line								
Input Voltage Range ¹	%	±15, (maxim working range : 290Vac~498Vac)								
Frequency	Hz	50/60 Hz								
Input Frequency Range	Hz	45~65								
Rated Power Input ²	kVA	12	18	25	37	49	74	98	123	148
Rated Power Input ²	A	18	28	37	56	74	112	148	185	224
Rated Power Input ³	kVA	15	23	31	46	61	92	122	153	185
Rated Power Input ³	A	23	25	46	70	93	140	186	232	280
Power Stepping Time ⁴	s	5~300								

Note:

1. Use recommended number of batteries. At the -15% voltage, UPS can guarantee maintaining the specified output voltage at rated load without discharging, but cannot guarantee the float charge voltage for the battery.
2. IEC62040-3(5.2.2): UPS, at rated load, and input rated voltage 380V, without battery charging current.
3. IEC62040-3 (5.2.2): UPS, at rated load or overload, and input rated voltage 380V, battery equalizing charging at maximum current.
4. Set by the diagnosis software.

8.5 UPS Electrical Characteristics (DC BUS)

Table 8-5 Electrical Characteristics (DC BUS)

Item	Unit	Rated Power (kVA)								
		10	15	20	30	40	60	80	100	120
Voltage range for inverter	Vdc	320~490								
Recommended number of lead-acid cells	piece	192								

Recommended floating charge voltage 2.25V/cell	Vdc	432
Recommended equalizing charge voltage 2.35V/cell	Vdc	451
Maximum manual charge voltage 2.40V/cell	Vdc	461
Battery protective voltage 2.45V/cell	Vdc	471
Maximum duration for equalizing charging ¹	min	480~1800
Threshold current for equalizing and floating charge ¹	A	0.001C~0.025C
Ripple voltage ²	%	≤1

Note:

1. Set up by software.
2. Without being connected to the battery, the percentage of the effective value of ripple voltage to the DC voltage

8.6 UPS Electrical Characteristics (Inverter Output)

Table 8-6 Electrical Characteristics (Inverter Output)

Item	Unit	Rated Power(kVA)								
		10	15	20	30	40	60	80	100	120
Rated Output Voltage ¹	Vac	380/400/415								
Type of Output Power Type	-	three-phase with neutral cable								
Frequency ²	Hz	50/60								
Rated power when power factor is 0.9	kVA	10	15	20	30	40	60	80	100	120
Rated power when power factor is 1	kW	9	13.5	18	27	36	54	72	90	108
Duration of three-phase overload ³	Min, I/In	60, 1.10 10, 1.25 1, 1.5								
Maximum non linear load allowed ⁴	-	100%Pn								
voltage stability, steady state test ³	%	±1								
voltage stability, transient state test ⁵	%	±5								
Max rate of change for	Hz/s	0.1								

frequency ⁶		
<p>Note:</p> <ol style="list-style-type: none"> 1. Factory setting is 380V, 400V or 415V, which can be set through the software. 2. Factory setting is 50Hz; 60 Hz can be set through the software. 3. IEC62040-3 (5.3.2) 4. IEC62040-3 (ANNEX E) 5. IEC62040-3 (5.3.1), including 0-100-0% load transient. Transient recovery time is 20ms, with an accuracy of 1% 6. Factory setting is 0.1 Hz/s; 1Hz/s can be set through the software. 		

8.7 UPS Electrical Characteristics (Bypass Input)

Table 8-7 Electrical Characteristics (Bypass Input)

Item	Unit	Rated Power (kVA)								
		10	15	20	30	40	60	80	100	120
Rated Voltage ¹	Vac	380/400/415								
Power Type	-	three-phase with neutral cable								
Rated Current	A									
380 Vac		15	23	30	46	60	92	120	152	182
400 Vac		14	22	29	44	58	88	108	145	174
415 Vac		13	21	28	42	56	84	104	139	167
Bypass Voltage Tolerance ²	%	Default upper limit 20%, default lower limit -40%								
Confirmation time for bypass voltage recovery	s	2								
Inverter Output Voltage window	%	±5								
Frequency ³	Hz	50/60								
Input Frequency Tolerance ⁴	%	±10								
Max change rate of synch frequency	Hz/s	1								
Current rating of neutral cable	-	1.3In								
Protection, bypass	-	External protector to be installed at the input distribution system of bypass, and its capacity should be distinguished form that of load protection.								
Transient Overload	ms I/In	10 14.3	20 12.6	50 11.0	100 10.0	200 9.0	500 8.0	1000 7.1	2000 6.6	5000 5.7

<p>Note:</p> <ol style="list-style-type: none"> 1. Factory setting is 380V. 400V or 415V can be set through the software. 2. Other values between -40%~20% can be set up through the software. 3. Factory setting is 50Hz; 60 Hz can be set through the software. 4. Other values between -5%~5% can be set through the software. 										
---	--	--	--	--	--	--	--	--	--	--

9. Maintenance and Repair

Regular maintenance and repair is necessary during the long-term operation of the UPS system (including the batteries). The maintenance and repair for the batteries have been elaborated in Chapter 6, so this section mainly introduces the service life and characteristics of the key components of the UPS system and offers suggestions on their regular check, maintenance and replacement. An effective maintenance can prolong the service life and lower the risk of breakdown.

9.1 Safety



The daily inspection of the UPS system can be conducted by trained personnel, while inspection and replacement of the components should be done by authorized service personnel.

9.2 UPS Key Components and the Service Life

Due to abrasion, the service life of some components in the UPS system may be shorter than that of the UPS. For the safety of the UPS power supply, the components need to be checked regularly and replaced when necessary. This section introduces the key components in the UPS system and their reference service life. For the UPS system under different operating conditions (environment, load rate etc.), please invite professional personnel to make assessment according to the information provided in this section, and offer suggestions on whether the parts need to be replaced.

9.2.1 Magnetic: Transformer and Inductor

The designed service life for the magnetic components is 20 years. The insulation used in the winding process and the temperature rise during operation are key factors that influence the service life. Our UPS uses Class H insulation, which can withstand a temperature as high as 180°C under the forced cooling condition.

9.2.2 Power Semiconductor

Power semiconductors, including silicon controlled rectifier (SCR) or insulated gate bipolar transistor (IGBT), do not have a rated service life under normal working conditions. The SCR and IGBT failures are generally triggered by other faults, yet the SCR and IGBT themselves will not be expired for service. During the annual preventive maintenance cycle, semiconductor devices should be visually inspected for corrosion and damage to the shell. If any corrosion or shell damage is found, the device should be replaced.

9.2.3 Electrolytic Capacitor

The actual service life for electrolytic capacitors mainly depends on the DC bus voltage and the ambient temperature of the UPS.

To ensure the steady power supply of the UPS, an annual inspection of the electrolytic capacitors is recommended. The electrolytic capacitors should be replaced before the end of its service life, which is suggested to be about 5~6 years.

9.2.4 AC Capacitor

The AC Capacitor is recommended to be replaced after 5~6 years of continuous operation. It is suggested that all AC capacitors be inspected every six months. If any distortion is found, the device should be replaced.

9.2.5 Service Life for the UPS Key Components

The key components in Table 9-1 are used in a UPS system. In order to prevent wear-out failure that may affect proper functioning, these components are suggested to be inspected regularly, and replaced before their expected service life.

Table 9-1 UPS Key Components' Service Life Parameter and Recommended Time of Replacement

Key Components	Expected Service Life	Suggested Replacement Period	Suggested Inspection interval
Power AC capacitor	≥7 years (≈62,000 hrs)	5~6years	6 months
Electrolytic Capacitor	≥7 years (≈62,000 hrs)	5~6years	1 year
Fan	≥7 years (≈62,000 hrs)	5~6years	1 year
Air-strainer	1~3 years	1~2years	3 months
Valve-regulated, lead-acid cell (5 years service life)	5 years	3~4years	6 months
Valve-regulated, lead-acid cell (10 years service life)	10 years	6~8years	6 months

9.2.6 Change Fuse

The fuses must be replaced with the same type on the high voltage interface board.