



www.ensmartpower.com

UNITED KINGDOM

Kemp House 160 City Road,
London, EC1V 2NX, ,United Kingdom
t: +44 20 3808 85 60
E: sales@ensmartpower.com

TURKEY

Kayisdagi Cad. No:1/5, Atasehir
Istanbul –Turkey 34752
t: +90 216 225 84 66
E: sales@ensmartpower.com

Follow us on



/ensmartpower



/ensmart_power



/ensmartpower



/ensmartpower

4256-6913A



SmartPack-UPS

Models 1kVA-2kVA-3kVA

220/230/240 VAC, 50/60 Hz Tower Version

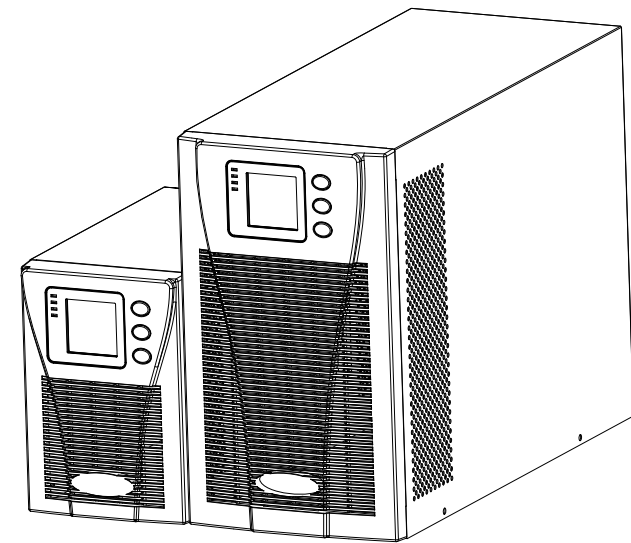

User Manual

FOREWORD

Thank you for choosing this product of **SMARTPACK-UPS 1-3kVA** range.

EnSmart Power is highly specialised in the development and production of uninterruptible power supplies (UPS). The UPS device described in this manual is designed and manufactured with care to guarantee uninterrupted power for your equipments and give you the best performance.

This manual contains detailed instructions for product use and installation.

For information on using and getting the best performance from your UPS, this manual must be stored in a safe place and CONSULTED BEFORE TAKING ANY ACTION ON THE UPS.

Please obey the instructions and all the warning stated in the manual or on the UPS. Do not run the UPS before finishing reading the safety and operation instructions.

Note: Because of the continuous improvements, our products may differ somewhat from the contents included in this manual. You can contact local office to get the information when necessary.

CONTENTS

1.Safety instruction.....	1
1.1 Safety instruction.....	1
1.2 Symbols indication	1
2.Product Introduction	3
2.1 The appearance of the product	3
2.2 The principle of the product.....	4
2.3 Model	4
3.Installation	5
3.1 Unpacking and inspection	5
3.2 Notes.....	5
3.3 UPS input connection.....	5
3.4 UPS output connection	6
3.5 Long backup external battery connection.....	6
4.Panel display, operation and running	8
4.1 Faceplate display illumination	8
4.2 Operation	11
4.3 Parameter setting	12
4.4 Parameters inquiring	20
4.5 Run mode	22
5.Maintenance	25
6.Troubleshooting and performance of product	26
6.1 LED indication and warning table.....	26
6.2 Troubleshooting	28
6.3 EMC standard/Safety standard	29
6.4 Product Performance	29
6.5 Communication interface	31

1. Safety instruction

Abstract

This chapter mainly introduce the safety marks and notes of 1KVA-3KVA series on-line UPS. Read this chapter carefully before operating on the equipment.

1.1 Safety instruction



There is dangerous voltage and high temperature inside the UPS. During the installation, operation and maintenance, please abide the local safety instructions and relative laws, otherwise it will result in personnel injury or equipment damage. Safety instructions in this manual act as a supplementary for the local safety instructions.

Our company will not assume the liability that caused by disobey of safety instructions. Please note the following:

1. Don't use the UPS when the actual load exceeds the rated load.
2. There are high-capacity batteries in the standard type UPS. You mustn't open the enclosure or it will lead to electric shock. If it needs internal maintenance or battery replacement, please send it to the designated site.
3. Internal short-circuit of the UPS will cause electric shock or fire. So don't place the containers equipped with liquid on the top of the UPS so as not to cause danger of electric shock and so on.
4. Don't put the UPS in a place with high temperature or humidity as well as the corrosive gas, much dust.
5. Keep good air circulation between in-vent on front panel and out-vent on back panel.
6. Avoid direct sunlight or near heat-dispersed objects.
7. In case that the smoke appears on the UPS, please cut off the power as soon as possible and contact the dealer service site.

1.2 Symbols indication

The safety symbols cited in this manual are shown in table 1-1, which are used to inform readers of safety issues that should be obeyed when installation, operation and maintenance.

Safety Symbol	Indication
	Attention
	Static discharge sensitive
	Electric shock

There are three levels of safety grade: Dangerous, Warning and Attention. The remark is on the right side of the safety symbol, the detailed comments is behind, shown as following:



Dangerous

Indicate risk of serious injury or death or seriously damage the equipment



Warning:

Indicate risk of serious injury or damage the equipment.



Attention:

Indicate risk of injury or damage the equipment.

2. Product Introduction

2.1 The appearance of the product

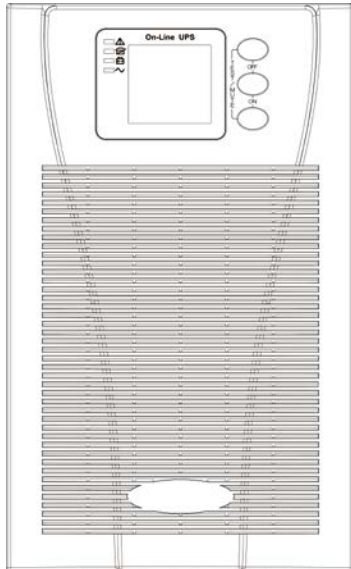

FIG.1 Front Panel view

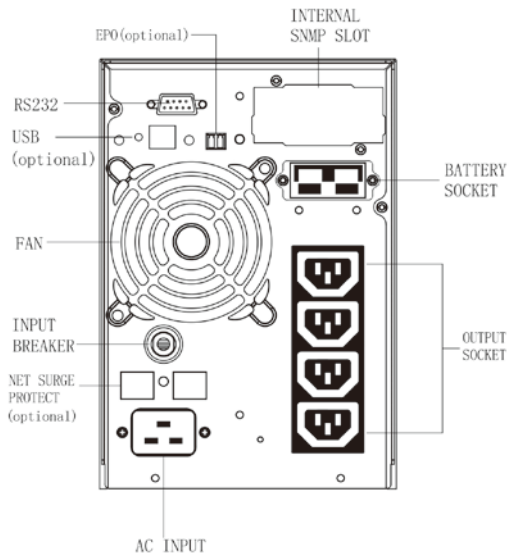

FIG.2 1kVA Rear Panel view

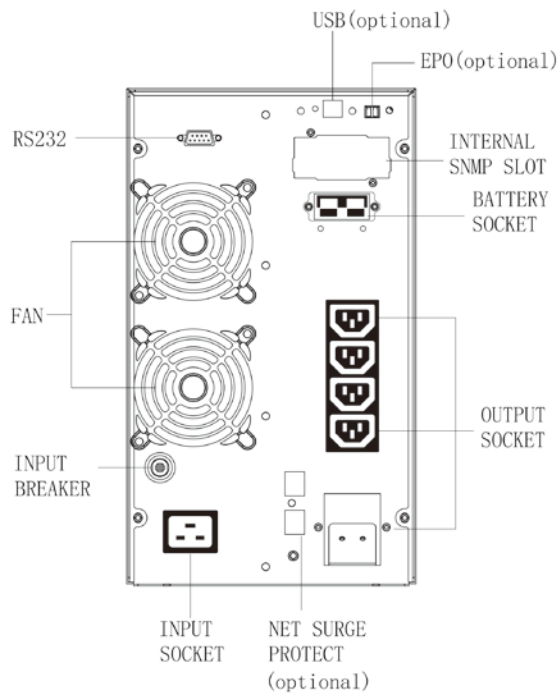

FIG.3 2/3kVA Rear Panel view

2.2 The principle of the product

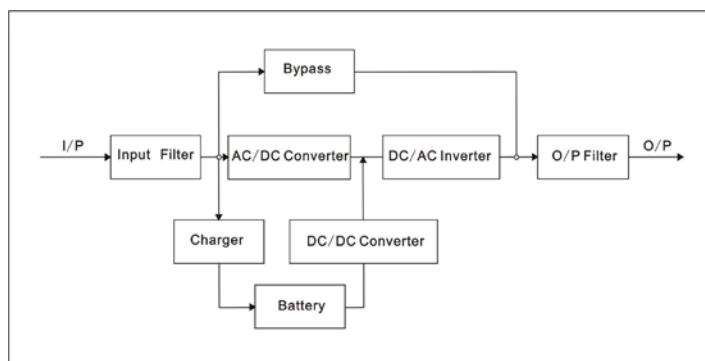

FIG.4 UPS Principle Diagram

1. Input filter: Complete filtering the input AC utility power to provide the clean power for UPS.
2. AC/DC converter: Convert the filtered AC mains to DC and boost the DC for DC/AC inverter.
3. DC/DC booster: When the UPS works in battery mode, the circuit boosts the DC for DC/AC inverter.
4. DC/AC inverter: Convert the boosted DC to stable AC output.
5. Bypass: When overload or failure of inverting happen in the UPS, it transfers to bypass mode to supply power to loads.
6. Charger: Standard unit provides 1A.
7. Battery: Sealed Lead Acid Battery.
8. Output filter: Complete filtering the output of the UPS to provide the clean power for loads.

2.3 Model

UPS sort	MODEL NO	Remark
Standard unit	1KVAS	Internal 1A charger, 2/3 PCS 9AH batteries
	1KVAH	Internal 6/12A charger, 3 PCS batteries
	2KVAS	Internal 1A charger, 4/6/8 PCS 9AH batteries
	2KVAH	Internal 6/12A charger, 6/8 PCS batteries
	3KVAS	Internal 1A charger, 6/8 PCS 9AH batteries
	3KVAH	Internal 6/12A charger, 6/8 PCS batteries

3. Installation

3.1 Unpacking and inspection

1. Unpacking the UPS and check that whether it's damaged during the transportation. If damaged or some parts missing, don't start the machine and inform the carrier and franchiser.
2. Check the annex (please consult Appendix Table 1).
3. Check if the equipment is just what you wanted to purchase. You can affirm through inspecting the model number on back panel of the equipment.

3.2 Notes

1. Please place the UPS in a clean, stable environment, avoid the vibration, dust, too humidity, flammable gas and liquid, corrosive.
2. The ambient temperature around UPS should keep in a range of 0°C ~ 40°C. If UPS works above 40°C, it is required that the rated value of the largest load decreases 12% while the temperature increases every 5°C. The highest temperature cannot be more than 50°C when UPS works.
3. UPS should be placed in a sufficiently ventilated place.

3.3 UPS input connection

Connect the UPS to the mains by input power cable which is equipped with the UPS.

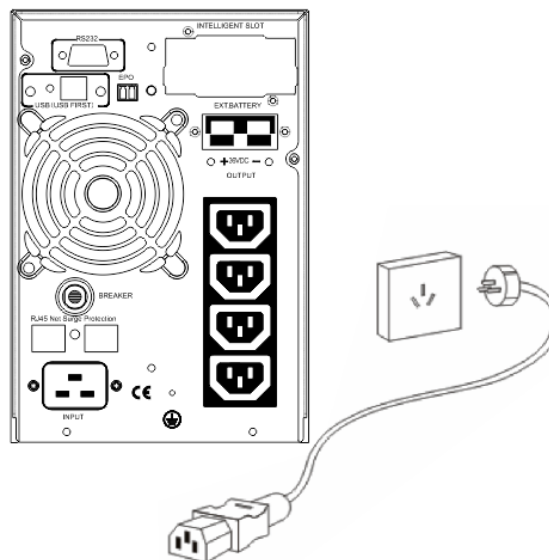

FIG.5 Input Connection

3.4 UPS output connection

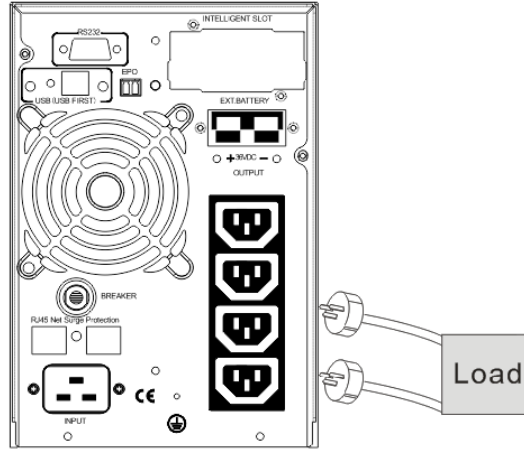
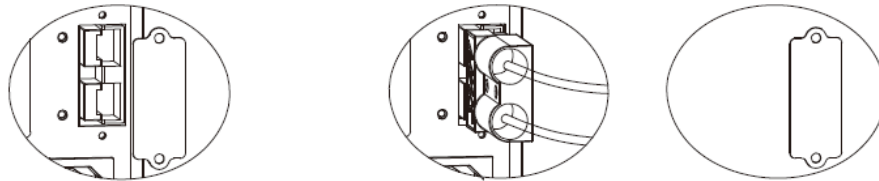
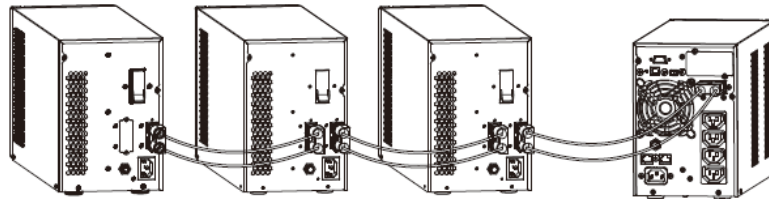

FIG.6 Output connection

3.5 To install the optional EBP(s) for a UPS(Standard unit):



Remove cable retention clip. Plug in EBP cable. Retain the clip.



1KVA Tower UPS and EBP (S)

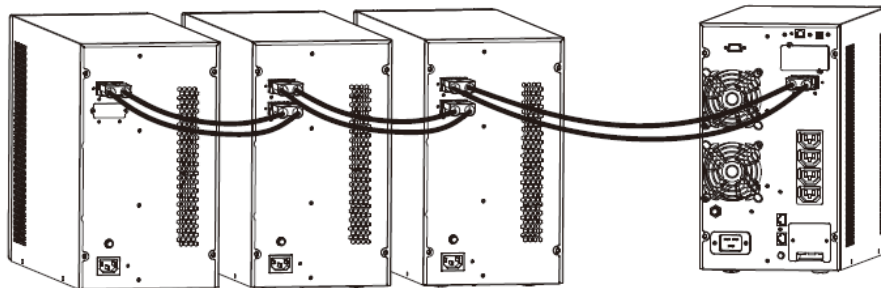

2KVA/3KVA Tower UPS and EBP (S)

3.6 Long backup external battery connection

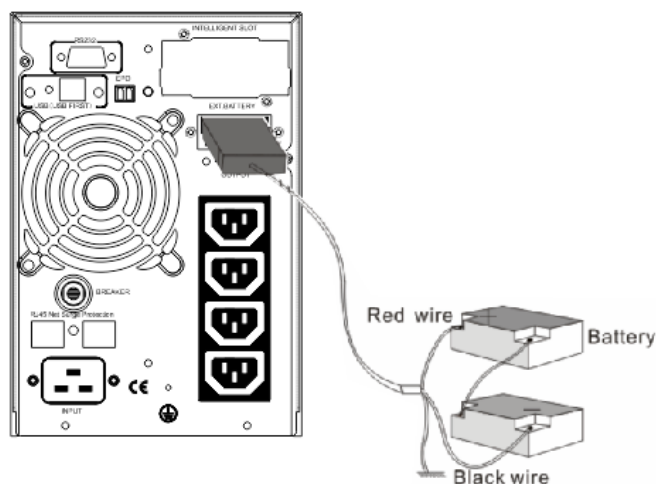

FIG.7 battery connection

⚠ Warning:

- ★ Before installing battery, make sure that UPS and breaker are all turned off. Remove all your metallic adornment such as finger ring, watch, and so on before connecting battery.
- ★ No anti-connection or short circuit between the battery anode and cathode forever. Red cable connect with battery anode “+” and black cable connect with cathode “-”.
- ★ Please use the screwdriver with insulating handle. Do not lay the tools or metallic goods on the battery.

⚠ Notice:

- ★ When using the external battery, It is best to use external battery cable which matches with the equipment.
- ★ When connecting load to UPS, first turn off load and then connect the power cable and finally turn on load one-by-one.
- ★ Inductance loads such as motor, fluorescent lamp, photocopier are strictly prohibited connecting to UPS to avoid damage.
- ★ Plug UPS on the special socket with over-current protection, the power socket that used should be connected with ground wire.
- ★ UPS is likely to have output voltage no matter whether the power input cable is plugged in mains input socket. If you wish UPS have no output, first break off the switch and then cancel the mains.
- ★ When connect laser printer, select the capacity of UPS according to the UPS start power because the startup power is higher.

4. Panel display, operation and running

The operation is simple, operators only need to read the manual and follow the operation instructions listed in this manual without any special training.

4.1 Faceplate display illumination

4.1.1 Keys function

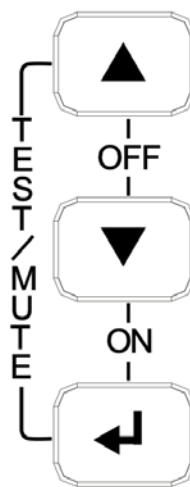

FIG.8 front panel buttons instruction

ON key ( + )

Press and hold this key for more than half a second to turn on the UPS.

OFF key ( + )

Press and hold this key for more than half a second to turn off the UPS.

TEST/MUTE key ( + )

Press and hold the key for more than 1 second in Line mode or economical mode: UPS runs the self-test function.

Press and hold the key for more than 1 second in battery mode: UPS runs the mute function.

INQUIRING key  or 

Non-function setting mode:

Press and hold the key for more than half a second (less than 2 seconds): Indicate the items of the LCD item section orderly.

Press and hold this key for more than 2 seconds: Circularly and orderly display the items every 2 seconds, when press and hold the key for some time again, it will turn to output status.

Function setting mode:

Press and hold the key for more than half a second (less than 2 seconds): Select the set option.

Function setting key 

Non-function setting mode:

Press and hold the key for more than 2 seconds: Function setting interface.

Function setting mode:

Press and hold the key for more than half a second (less than 2 seconds): Affirm the set option.

Press and hold the key for more than 2 seconds, exit from this function setting interface.

4.1.2 The function of LED indicators

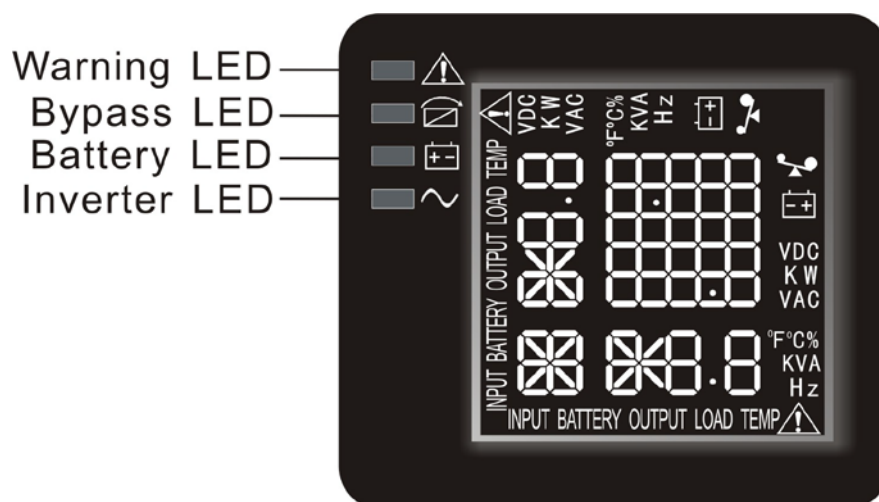

Warning red LED is on: UPS is fault. For example: Overload beyond the allowed time, inverter fault, BUS fault, over temperature fault etc.

Bypass yellow LED is on: UPS is alarming. For example: Bypass mode supply power and etc.

Battery yellow LED is on: UPS is alarming. For example: Battery mode supply power and etc.

Inverter green LED is on: UPS is normally powered by mains or ECO mode or battery mode.

After starting the UPS, the four LEDs will light and go out one-by-one. It circulates several times until starting the UPS successful.

NOTE: As to the LED indication in different modes, please refer to the LED display panel and warning table.

4.1.3 LCD display functions

The LCD displays as following Fig.



LCD display comprises numerical value section, capacity graphics section, fan-status graphics section and charger-status graphics section.

Numerical value section—display the corresponding numerical value of inquiring items(output, load, temperature, input, battery), for example, as the graphics shows above, the output voltage is 230v, the output frequency is 50Hz.

Capacity graphics section—display the capacity of the battery and load. Every pane represents 20%capacity. As graphics shown above, the load reaches 80%-100%(5 panes), the capacity of the battery is 40%-60%(3 panes). When UPS is overload, the icon will flash, when capacity of battery is too low or disconnected, the icon will also flash.

Fan-status graphics section—display if the fan works normally. When the fan works normally, it will show the dynamic fan blades rotating; when the fan works abnormally, the icon  will keep on flashing with the warning .

Charger-status graphics section—display the status of the charger. When charger works normally, the corresponding icon will vary dynamically and orderly, just as Graphics (1);



(1)

when charger works abnormally, the icon will flash in a whole, as Graphics(2):

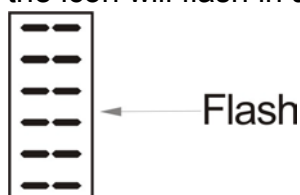

(2)

When UPS is in battery mode, the number of the icons of the charger-state section will vary according to the changeable capacity of the battery (pane). For example, there are five panes in Fig.A,(as the right picture of the Graphics(3) shows), so the corresponding number of icons is five rows(as the left picture of the Graphics(3) shows),, followed by this rule,



(3)

4.2 Operation

4.2.1 Start up operation

Turn on the UPS in line mode

- ① Once mains power is plugged in, the UPS will charge the battery, at the moment, LCD shows that the output voltage is 0, which means UPS has no output. If it is expected to have output of bypass, you can set the bps “ON” by LCD setting menu.
- ② Press and hold the ON key for more than half a second to start the UPS, then it will start the inverter.
- ③ Once started, the UPS will perform a self-test function, LED will light and go out circularly and orderly. When self-test finishes, it will come to line mode, the corresponding LED lights, UPS is working in line mode.

Turn on the UPS by DC without mains power

- ① When mains power is disconnected, press and hold the ON key for more than half a second to start UPS.
- ② The operation of UPS in the process of start is almost the same as that when mains power is in. After finishing the self-test, the corresponding LED lights and UPS is working in battery mode.

4.2.2 Turn off operation

Turn off the UPS in line mode

- ① Press and hold the OFF key for more than half a second to turn off the UPS and inverter.
- ② After UPS shutting down, LED go out and there is no output. If output is needed, you can set bps “ON” on LCD setting menu.

Turn off the UPS by DC without mains power

- ① Press and hold the OFF key for more than half a second to turn off the UPS.
- ② When turning off the UPS, it will do self-testing firstly. LED light and go out circularly and orderly until there is no display on the panel.

4.2.3 UPS self-test/mute test operation.



- ① When UPS is in line mode, press and hold the self-test/mute key for more than 1 second, LEDs light and go out circularly and orderly. UPS comes to self-test mode and tests its status. It will exit automatically after finishing testing, LED resume.
- ② When UPS is in battery mode, press and hold the self-test/mute key for more than 1 second, the buzzer stops beeping. If you press and hold the self-test/mute key for one more second, it will restart to beep again.

4.3 Parameter setting

UPS has setting function. It can run the setting on any mode. After setting, it will become effective at once when meets some standards. The set information can be saved only when the battery connected and normally turning off the UPS.



The operation of setting is as following:

4.3.1 ECO mode setting(1)

- ① Enter the setting interface. Press and hold the function setting key  for more than 2 seconds, then come to setting interface, the letters “ECO” will flash
- ② Enter the ECO setting interface. Press and hold the function setting key  for more than half a second (less than 2 seconds), then come to setting interface of ECO, at this time, the letters “ECO” will light for a long time. The “ON”(or OFF) below the ECO will flash. Press and hold the inquiring key  for more than half a second (less than 2 seconds) to determine whether the ECO function is used or not. If used, the corresponding word is “ON”, if not, the word is “OFF”. It can be determined by yourself.





③ Confirm the ECO selecting interface. After selecting ON or OFF, press and hold the function setting key  for more than half a second (less than 2 seconds). Now, the ECO setting function is completed and the “ON” or “OFF” below the “ECO” will light without flash.

④ Set the ECO tolerance range. Short press the scroll key  or  for more than half a second (shorter than 2 seconds) to select the voltage range in percentage. +5%,+10%,+15%,+25%(default is +25%), then short press function setting key  for more than half a second (shorter than 2 seconds) to confirm the selection, then to set the minus range

⑤ To set the minus range in the same way.

⑥ Exit from the setting interface. Press and hold function setting key  for more than 2 seconds, exit from the setting interface and turn to main interface.

4.3.2 Bypass mode setting(2)



① Enter the setting interface. Press and hold the function setting key  for more than 2 seconds, then come to setting interface, Press and hold the function setting key  for more than half a second (less than 2 seconds), select the function setting, choose the bypass output interface, at the moment, the letters “bPS” will flash



② Enter the Bypass output selecting interface. Press and hold the function setting key  for more than half a second (less than 2 seconds), then come to setting interface of bPS, at this time, the letters “bPS” will light for a long time. The “ON”

below the bPS will flash. Press and hold the inquiring key  for more than half a second (less than 2 seconds) to determine whether the bPS function is used or not. If used, the corresponding word is “ON”, if not, the word is “OFF”. It can be determined by yourself.

③ Confirm the Bypass output selecting interface. After selecting ON or OFF, press and hold the function setting key  for more than half a second (less than 2 seconds), Now, the bPS setting function is completed and the “ON” or “OFF” below the “bPS” will light without flash.



④ Set the BPS tolerance range. Short press the scroll key  or  for more than half a second (shorter than 2 seconds) to select the voltage range in percentage. +5%,+10%,+15%,+25%(default is +25%), then short press function setting key  for more than half a second (shorter than 2 seconds) to confirm the selection, then to set the minus range

⑤ To set the minus range in the same way.

⑥ Exit from the setting interface. Press and hold function setting key  for more than 2 seconds, exit from the setting interface and return to main interface.

⑦ After setting bPS as ON, when mains power plugged in without turning on the UPS or no mains power plugged in, there is bypass output but no power down backup function.

4.3.3 Output voltage setting(3)

① Enter the setting interface. Press and hold the function setting key  for more than 2 seconds, then come to setting interface, Press and hold the inquiring key  for more than half a second(less than 2 seconds), select the function setting, choose output voltage setting interface, at the moment, the letters “OPU” will flash



② Enter the output voltage selecting interface. Press and hold the function setting key  for more than half a second(less than 2 seconds), then come to setting interface of output voltage OPU, at this time, the letters “OPU” will light for a long time.



The numerical value below the OPU will flash. Press and hold the inquiring key  for more than half a second (less than 2 seconds), select the numerical value in accordance with “OPU” function. The provided voltages are 208V,220V, 230V, 240V you can choose anyone by yourself (The default is 220v).

③ Confirm the output voltage selecting interface. After selecting numerical value, press and hold the function setting key  for more than half a second (less than 2 seconds). Now, the OPU setting function is completed and the numerical value below the “OPU” will light without flash.



④ Exit from the setting interface. Press and hold function setting key  for more than half a second (less than 2 seconds), exit from the setting interface and return to main interface.

NOTE:When setting the output voltage, you'd better cut off the load of the UPS first.

4.3.4 Battery Pack (EBP) number and type setting(4)

① Enter the setting interface. Press and hold the function setting key  for more than 2 seconds, then come to setting interface, Press and hold the scroll key  for more than half a second(less than 2 seconds), select the function setting, choose battery setting interface, at the moment, the letters “bAt” will flash.





② Enter the battery setting interface. Press and hold the function setting key  for more than half a second(less than 2 seconds), then come to setting interface of battery, the letters “bAt” will stop flashing. The numerical value below the “bAt” will flash. Press and hold the scroll key  for more than half a second (less than 2 seconds), select the numerical value in accordance with the real connected battery packs.

③ Confirm the battery packs setting interface.





After selecting numerical value, press and hold the function setting key  for more than half a second (less than 2 seconds). Now, the battery packs setting is confirmed and the battery type value below will flash。

- ④ set the battery type in the same way.
- ⑤ Exit from the setting interface. Press and hold function setting key  for more than half a second (less than 2 seconds), exit from the setting interface and return to main interface.



4.3.5 Load segment setting (5)



- ① Enter the setting interface. Press and hold the function setting key  for more than 2 seconds, then come to setting interface, Press and hold the scroll key  for more than half a second (less than 2 seconds), select the function setting, choose battery setting interface, at the moment, the letters “Seg 1” will flash.



- ② Enter the load segment setting interface. Press and hold the function setting key  for more than half a second (less than 2 seconds), then come to setting interface of load segment, the letters “Seg 1” will stop flashing. The numerical value below the “Seg 1” will flash. Press and hold the scroll key  for more than half a second (less than 2 seconds), select the battery voltage, 10.5v, 11.0v, 11.5v (default is 10.5v)。
- ③ Confirm the power shedding shielding battery voltage setting. After selecting numerical value, press and hold the function setting key  for more than half a second (less than 2 seconds). Now, the load shielding battery voltage setting is confirmed.
- ④ Exit from the setting interface. Press and hold function setting key  for more than half a second (less than 2 seconds), exit from the setting interface and return to main interface.

4.3.6 Automatic Battery Test mode setting(6)

① Enter the setting interface. Press and hold the function setting key  for more than 2 seconds, then come to setting interface, Press and hold the inquiring key  for more than half a second (less than 2 seconds), select the function setting, choose Automatic Battery Test setting interface, at the moment, the letters “Abt” will flash

② Enter the “Abt” setting interface. Press and hold the function setting key  for more than half a second (less than 2 seconds), then come to setting interface of “Abt”, at this time, the letters “Abt” will light for a long time. The “ON”(or OFF) below the “Abt” will flash. Press and hold the inquiring key  for more than half a second (less than 2 seconds) to determine whether the “Abt” function is used or not. If used, the corresponding word is “ON”, if not, the word is “OFF”. It can be determined by yourself.





③ Confirm the “Abt” selecting interface. After selecting ON or OFF, press and hold the function setting key  for more than half a second (less than 2 seconds). Now, the “Abt” setting function is completed and the “ON” or “OFF” below the “Abt” will light without flash.

④ Exit from the setting interface. Press and hold function setting key  for more than half a second (less than 2 seconds), exit from the setting interface and return to main interface.

If used, the corresponding word is “ON”, One month periodically check the battery connections.

4.3.7 Warning Code Display mode setting(7)

① Enter the setting interface. Press and hold the function setting key  for more than 2 seconds, then come to setting interface, Press and hold the inquiring key  for more than half a second (less than 2 seconds), select the function setting, choose Warning Code Display setting interface, at the moment, the letters “wc” will flash

② Enter the “wc” setting interface. Press and hold the function setting key  for more than half a second (less than 2 seconds), then come to setting interface of “wc”, at this time, the letters “Abt” will light for a long time. The “ON”(or OFF) below the Abt

will flash. Press and hold the inquiring key  for more than half a second (less than 2 seconds) to determine whether the “wc” function is used or not. If used, the corresponding word is “ON”, if not, the word is “OFF”. It can be determined by yourself.

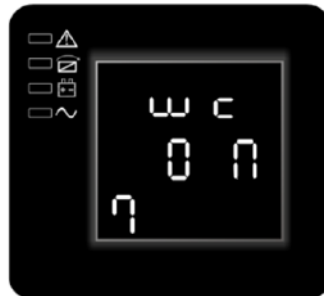





③ Confirm the “wc” selecting interface. After selecting ON or OFF, press and hold the function setting key  for more than half a second (less than 2 seconds). Now, the “wc” setting function is completed and the “ON” or “OFF” below the “wc” will light without flash.

④ Exit from the setting interface. Press and hold function setting key  for more than half a second (less than 2 seconds), exit from the setting interface and return to main interface.

If used, the corresponding word is “ON”, 2~5 seconds cycle Warning Code, please refer to Warning Code information Table in Appendix 1.

4.3.8 EPO Input Polarity setting (8)

① Enter the setting interface. Press and hold the function setting key  for more than 2 seconds, then come to setting interface, Press and hold the scroll key  for more than half a second (less than 2 seconds), select the function setting, choose EPO Input polarity setting interface, the letters “EPO” will flash.



② Enter the EPO Input Polarity setting interface. Press and hold the function setting key  for more than half a second (less than 2 seconds), the letters “EPO” will stop flashing. The letters below the “EPO” will flash. Press and hold the scroll key  for more than half a second (less than 2 seconds), select the EPO input polarity, “+P”(open circuit execute EPO function) or “-P”(short circuit execute EPO function)



③ Confirm the setting. After selecting EPO input polarity, press and hold the function setting key  for more than half a second (less than 2 seconds). Now, the setting is confirmed.



④ Exit from the setting interface. Press and hold function setting key  for more than half a second (less than 2 seconds), exit from the setting interface and return to main interface.

4.3.9 (Battery) End of discharge setting (9)

① Enter the setting interface. Press and hold the function setting key  for more than 2 seconds, then come to setting interface, short press the scroll key  for more than half a second (less than 2 seconds) to select Eod setting, the letters “Eod” will flash.



② Enter the Eod setting interface. Press and hold the function setting key  for more than half a second (less than 2 seconds) at this time, the letters “Eod” will stop flashing.





③ Set the Eod tolerance range. Short press the scroll key  or  for more than half a second (shorter than 2 seconds) to select the voltage range in percentage. 10.0V, 10.5V, 11.0V (default is 10.0V), then short press function setting key  for more than half a second (shorter than 2 seconds) to confirm the selection, then to set the minus range

④ After the minus range is confirmed. Long press function setting key  for more than 2 seconds to exit setting menu..

4.3.10 Frequency Converter mode setting (10)

① Enter the setting interface. Press and hold the function setting key  for more than 2 seconds, then come to setting interface, Press and hold the scroll key  for more than half a second (less than 2 seconds), select the function setting, choose output frequency setting interface, the letters “OPF” will flash.



② Enter the output frequency of converter mode setting interface. Press and hold the function setting key  for more than half a second (less than 2 seconds), the letters “OPF” will stop flashing. The letters below the “OPF” will flash. Press and hold the scroll key  for more than half a second (less than 2 seconds), select the output frequency, “50Hz”(output fixed to 50Hz and active converter mode) or “60Hz”(output fixed to 60Hz and active converter mode) or “IPF”(inactive converter mode and active normal mode)

③ Confirm the setting. After selecting converter mode output frequency, press and hold the function setting key  for more than half a second (less than 2 seconds). Now, the setting is confirmed.



④ Exit from the setting interface. Press and hold function setting key  for more than half a second (less than 2 seconds), exit from the setting interface and return to main interface.

IPF:UPS output frequency with the same frequency as the mains input.

50.0Hz:UPS output frequency is fixed at 50.0Hz, independent of the mains input frequency

60.0Hz:UPS output frequency is fixed at 60.0Hz, independent of the mains input frequency.

4.4 Parameters inquiring

Press and hold the inquiring key  or  for more than half a second (less than 2 seconds) to inquire about items. The inquired items include input, battery, output, load, temperature, versions. The displayed items on LCD screen are showed as following:

Output: Display the output voltage and output frequency of the UPS. As the following graphic shows, the output voltage is 230v, the output frequency is 50Hz.



Load: Display the numerical value of the active power(WATT) and apparent power(VA) of the load. For example, as the following graphics shows: the WATT of the load is 100w, VA is 100VA (when disconnect load, it is a normal phenomenon to show a small numerical value of WATT and VA).

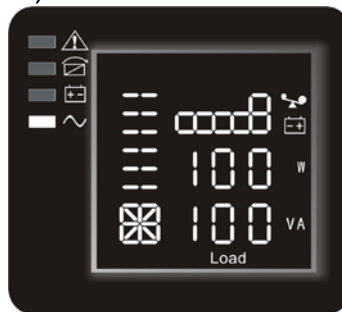

Temperature: Display the temperature of the inverter in the UPS. As the following graphics shows: the temperature of the inverter is 37°C.

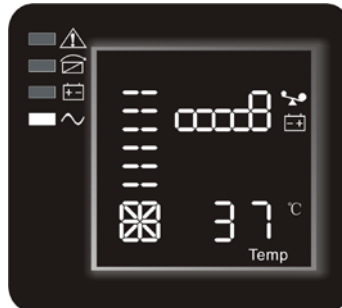

Input: Display the voltage and frequency of the input. As the following graphics shows: the input voltage is 210v, input frequency is 49.8Hz.



Battery: Display the voltage and capacity of the battery (determined by type). As the following graphics shows: the battery voltage is 28v, the capacity of battery is 100% (the capacity of battery is approximately reckoned according to the battery voltage).

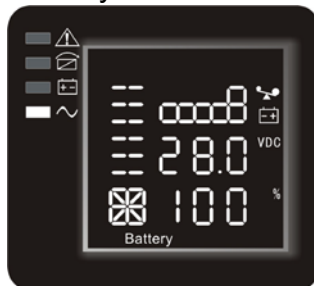

Battery remaining time: Display the battery remaining time when under battery mode. The number is from 0 to 999 minutes. As the following graphics shown: there are 686 minutes left for discharging.



System software Version: Display the system software version. As the following graphics shows: the System software Version is 04.

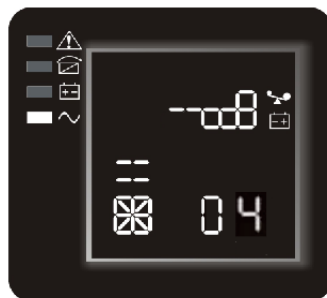

Press and hold the inquiring key  for more than 2 seconds, LCD begins to display the items circularly and orderly which transfer to another every 2 seconds. Press and hold the key for some time again, it will return to output status.

4.5 Run mode

4.5.1 Bypass mode

LED indications on front panel in bypass mode are as following:

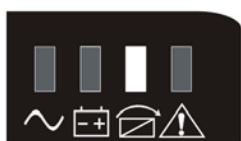

Bypass yellow LED is on, the buzzer beeps once every 2 minutes . The warning red LED is on when beeping, LCD displays are according to the exact load and battery capacity.

Turn to bypass mode under the following two conditions:

- ① Turn off the UPS in line mode while start the bypass output.
- ② Overload in line mode.

NOTE: When UPS is working in bypass mode, it has no back up function.

4.5.2 Line mode

LED indications on front panel in line mode are as following: The inverter green LED is on.

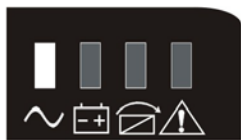

When input AC mains is in line with the working conditions, UPS will work in line mode.

4.5.3 Battery mode

LED indications on front panel in battery mode are as following: both the inverter green LED and battery yellow LED are on, the buzzer beeps once every 4 seconds. The warning red LED is on when beeping.



When the mains power down or instable, UPS will turn to battery mode at once.

4.5.4 ECO mode

LED indications on front panel on ECO mode are as following: both the inverter green LED and bypass yellow LED are on.

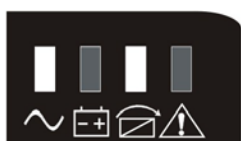

When the input mains meets the input range of the ECO mode and start the ECO function, the UPS will works on ECO mode. If input AC mains exceeds the range of ECO several times in a row in a minute but stays in inverter input range, UPS will work on AC inverting mode automatically.

4.5.5 Fault mode

LED indications on front panel in fault mode are as following: warning red LED is on

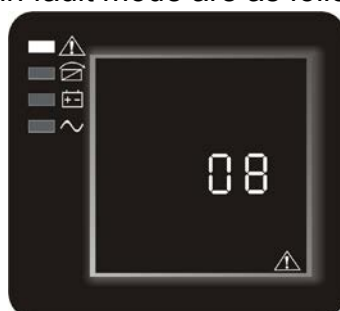

Fault mode (LCD interface on which the fault code display)

When UPS has fault. The warning LED is on and the buzzer beeps. UPS will turn to fault mode. UPS cuts off the output and LCD display fault codes. At the moment, you can press the mute key to make the buzzer stop beeping temporarily to wait for maintenance. You can also press the OFF key to shut down the UPS when confirm that there is no serious fault.

NOTE: As for corresponding information of the fault code, please refer to Fault Code information Table in Appendix1.

- ★The following process must be performed if UPS is connected with generator:
- ★First turn on generator, after it runs stably connect output power of generator to UPS input terminal, then turn on UPS. After UPS turned on, please connect load one-by-one.
- ★ It is recommended that the generator capacity is as twice as UPS rated capacity
- ★ You'd better not use the ECO mode when the quality of the input AC mains is not good.

5. Maintenance

Only minimum maintenance is required for this series of UPS. The battery is sealed lead acid maintenance free. It only needs to be kept charging to obtain the expected life. Whether it is started or not, the UPS would charge batteries once it is connected to mains and provide protection for over-charging and deep discharging.

5.1 Battery maintenance

- 1 It is recommended that the batteries are manually charged or discharged once every three or four months if UPS has not been used for a long time or the power is long-term uninterruptible. The battery will be fully discharge to low-voltage protection shutdown. Then it needs to be fully charged once.
2. In high temperature area, batteries should be manually charged and discharged once every two months. The process is the same as that said above.
3. Under normal circumstances of using, the battery working life is three to five years. If you find that the battery do not act well such as obviously shortening of backup time, too much imbalance on battery voltage so on, the battery should be replaced as soon as possible, which must be performed by qualified personnel.
4. When replace battery, it is recommended to change battery all together instead of changing separately.

NOTICE:

Before replacing batteries, first please turn off the UPS and break off the mains. Remove your metallic adornment such as finger ring, watch and so on.

When replace batteries, please use the screwdriver with insulating handle. Do not lay the tools or metallic goods on the battery.

Never reverse or short circuit between the battery anode and cathode

6. Troubleshooting and performance of product

The following messages are the information that users would find on UPS when it meets some problems. Users can judge if the fault is caused by external factors and know how to deal with it by making full use of the information.

1. Fault indicator on, indicates that the UPS has detected some faults.
2. Buzzer beeps, indicates that UPS need to be paid attention to, if beeps for a long time, it means that there is something wrong with the machine.
3. If you need help, contact our service department, the following messages should be provided for analysis:
 - ◆ UPS MODEL NO. and SERIAL NO.
 - ◆ Date of fault happened
 - ◆ Detailed description of the problem (include indicator statements on panel)

6.1 LED indication and warning table

Appendix1: Warning and Fault Codes

 WARNING Battery voltage low 1 Overload warning 2 Battery disconnect 3 Mains abnormal 4 Fan lock 5 Charger fail 6 Battery over 7 Bypass mode 8 Battery mode 9	FAULT CODES			
	Byp Mode	Line Mode	Bat Mode	BatTest Mode
Bus Fault	62	05、25	01、21	40、41
Inv Fault	61、63	04	24	42
Over Heat	33	06	08	43
OP Short	\	16	02	44
Overload	\	03	09	45
Fan Fault	36	28	38	46
Charge Fault	07	07	\	\
Bat Over	11	11	11	11

Appendix 2: The corresponding working status of indications

NO	Working status	Indication				Warning	Remarks
		Nor	Bat	Bps	Fau		
1	Line mode						
	Normal voltage	●				None	
	High/low voltage protection, turn to battery mode	●	●		★	Once every four seconds	

2	Battery mode						
	Normal voltage	•	•		★	Once every four seconds	
	Battery Voltage abnormal warning	•	★		★	Once per second	
3	Bypass mode						
	Main AC Normal voltage in bypass mode			•	★	Once every two minutes	Eliminate after starting the UPS
	Main AC high voltage warning in bypass mode				★	Once every four seconds	
	Main AC low voltage warning in bypass mode				★	Once every four seconds	
4	Battery disconnect warning						
	Bypass mode			•	★	Once every four seconds	Affirm if the battery switch is closed
	Inverting mode	•			★	Once every four seconds	Affirm if the battery switch is closed
	Power up or start					Six times	Affirm if the battery is connected well
5	Output overload protection						
	Overload warning in line mode,	•			★	Twice per seconds	Remove the less important loads
	Overload in line mode, protection			•	•	Long beeps	Remove the less important loads
	Overload warning in battery mode	•	•		★	Twice per second	Remove the less important loads
	Overload in battery mode, protection	•	•		•	Long beeps	Remove the less important loads
6	Overload warning in bypass mode			•	★	Once every 2 seconds	Remove the less important loads
7	Fan fault (fan icon flash)	▲	▲	▲	★	Once every 2 seconds	Check if the fan is blocked by object.
8	Fault mode				•	Long beeps	If display fault code and icon ▲lights, contact for maintenance when you can't deal with it by yourself.

• _indicator lights for a long time

★ _indicator flashes

▲ _the status of indicator depends on other conditions

NOTE: When UPS has fault, it is convenient for you to know the working status of UPS and the exact information about the fault promptly by referring to the two tables listed above.

6.2 Troubleshooting

When the fault occurs, firstly, perform troubleshooting by referring to the troubleshooting table. If the fault still exists, please contact the franchiser.

Fault	Cause	Solution
The "INPUT" letters on LCD display section flashes	Anti-connection of mains live and neutral or mains is out of range	Re-connect the input power cable and make a correct connection
Battery capacity indicator flashes	Battery low voltage or battery disconnected	Check UPS battery, connect battery well, if battery damaged, replace it
Mains normal, but UPS has no input	UPS input breaker open circuit	Press the breaker for reset
Short back up time	Battery not fully charged	Keep UPS connecting with mains power for more than 8 hours, recharge battery
	UPS overload	Check the usage of loads, remove some redundant devices
	Battery aged	When replace battery, contact franchiser to get battery and relative assembly
UPS doesn't startup after pressing the ON key	Didn't press the combination keys of "on"	Press the two keys at the same time
	UPS has no battery connected or battery voltage low and too many loads connected	Connect UPS battery well, if battery voltage low, please turn off UPS and remove some loads, then start UPS
	Fault occurs inside UPS	Contact supplier for servicing
The icon of charger status on LCD display flashes and buzzer beeps once per second	Charger doesn't work normally or battery aged	Contact supplier for servicing

6.3 EMC standard/Safety standard

◆Our product are manufactured according to the following EMC international grade standard and has passed the CE authentication:

EMC standard number	Safety standard number
IEC62040-2	IEC92040-1
IEC61000-4-2	GB4943-5
IEC61000-4-3	
IEC61000-4-4	
IEC61000-4-5	

6.4 Product Performance

Model		1KVAS/H	2KVAS/H	3KVAS/H	
Rated capacity		800/900W/1KVA	1600/1800W/2KVA	2400/2700W/3KVA	
input	input	Single phase and earthing			
	Voltage range	160-290VAC @ full load			
		140-290VAC @70% < load ≤ 80%			
		120-290VAC @60% < load ≤ 70%			
			110-290VAC @load ≤ 60%		
	Frequency range		46Hz-54Hz±0.5Hz@50HZ or 56Hz-64Hz±0.5Hz@60HZ		
	Power factor		≥0.98		
Current harmonic		< 7% (100% linear load)			
output	Output style		Single phase and earthing		
	Rated voltage		200/208/220/230/240VAC		
	Power factor		0.8/0.9		
	Voltage precision		±2%		
	Output Fre-quency	Line mode	1、 When input frequency is in the range, the output frequency Synchronized with the utility on AC mode. 2、 When input frequency is out of the range, the output frequency is (50/60 ± 0.2) Hz when turn to battery mode		
		Battery	(50/60 ± 0.2) Hz		
	Crest ratio		3:1		
	Transfer time		Mains ↔ battery = 0ms		
			Mains ↔ bypass < 4ms		
	Overload capacity		>110%, 30s turn to bypass mode;		
			>150%, 300ms turn to bypass mode		
efficiency	Line mode	Full load ≥ 90%			
	Battery mode	Full load ≥ 85%			

	ECO mod	Full load $\geq 94\%$		
	Output voltage distortion	$\leq 3\%$ (100% linear load)		
		$\leq 5\%$ (100% nonlinear load)		
Battery	Input battery voltage	24/36VDC	48/72/96VDC	72/96VDC
	Internal battery capacity	2/3	4/6/8	6/8
	Internal battery type	12V/9AH sealed lead acid maintenance free battery (only refers to standard UPS)		
	Backup time	Full load $\geq 4\text{min}$ (only refers to standard UPS) , As for long backup UPS, the backup time is determined by the capacity of battery.		
	Charge current (A)	1.2/6/12	1.2/6/12	1.2/6/12

◆ Work Environment

Model	1KVA-3KVA series
Ambient Temperature	0°C ~ 40°C
Relative humidity	0 ~ 95% non-condensing
Altitude	< 1500m. when > 1500m, lower the rated power for use
Store temperature t	-25°C ~ 55°C

◆ Mechanical Specification

Model	Battery voltage	Dimension W*D*H (mm)	Net weight/Gross weight(kg)
1KVAS	24VDC	144*400*215	9.3/10.3
	36VDC		12/13
1KVAH	24/36VDC		5.8/6.8
2KVAS	48VDC	191*470*336	18.8/20.8
	72VDC		23.8/25.8
	96VDC		28.8/30.8
2KVAH	72/96VDC		10/12
3KVAS	72VDC		23.8/25.8
	96VDC		28.8/30.8
3KVAH	72/96VDC		10/12

6.5 Communication interface

6.5.1 RS232 communication interface

This UPS provides a standard DB9 communication interface on its rear panel, the definition of the pins is as following:

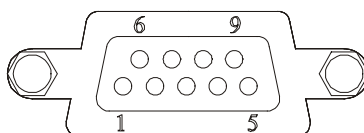

Pin	Definition
1、4、6、7、8、9	No use
2	Transmit
3	Receipt
5	GND

6.5.2 RS232 cable specifications

When connecting the UPS with PC by RS232 cable, it needs to use the standard RS232 cable, the detailed cable NO. are as following:

PIN 1 (hole) to computer serial	PIN 2 (needle) to UPS serial
2	2
3	3
5	5

6.5.3 Emergency Power-off

EPO is used to shut down the UPS from a distance. This feature can be used for shutting down the load and the UPS by thermal relay, for instance in the event of room overtemperature. When EPO is activated, the UPS shuts down the output and all its power converters immediately. The UPS remains on to alarm the fault.

There is also a front panel EPO option for user to initial EPO function by pressing the three switch on the front panel together. When the three switches is pressed down at the same time, the EPO function will be active, UPS will shut down and the buzzer will long beep. Pressing startup switches will not turn on the UPS unless the EPO function is deactivated by pressing the three switches together and press off switches to return normal status.

EPO Connections		
Wire Function	Terminal Wire Size Rating	Suggested Wire Size
EPO L1 _____	4–0.32 mm ² (12–22 AWG)	0.82 mm ² (18 AWG)
L2		



You can set the EPO polarity. See the “EPO Input Polarity” setting in “User Settings”

NOTE Depending on user configuration, the pins must be shorted or opened to keep the UPS running. To restart the UPS, reconnect (re-open) the EPO connector pins and turn on the UPS manually. Maximum resistance in the shorted loop is 10 ohm.

Always test the EPO function before applying your critical load to avoid accidental load loss.

Leave the EPO connector installed onto the EPO port of the UPS even if the EPO function is not needed.

6.5.4 Load Segments

Load segments are sets of receptacles that can be controlled by power management software or through the display, providing an orderly shutdown and startup of your equipment. For example, during a power outage, you can keep critical equipment running while you turn off other equipment. This feature allows you to save battery power.

Each UPS has two load segments:

- Load Segment 1: The power shedding battery voltage of this segment can be set by LCD.

- Load Segment 2.

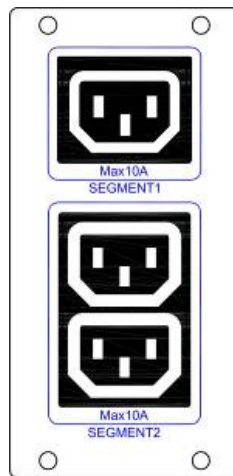

6.5.5 Optional communication interface

① USB communication interface

USB communication interface: Install the intelligent monitoring software UPSilon2000 which is equipped with the UPS. Then it can achieve the communication with monitoring device directly. When RS232 and USB are provided, only one of them will be chosen and USB is preferred.

② Intelligent slot

The following intelligent cards can be installed into the intelligent slot of the UPS: intelligent USB card, intelligent SNMP card and intelligent dry contact card. Support the hot plug and play. Any card of them can be used according to users' requirements.

- a) Intelligent USB card: Use the monitoring function of the USB interface system to monitor and manage the power source of the UPS.
- b) Intelligent SNMP card: When connecting to the internet by SNMP card, it communications with the monitoring computer to monitor power source of the UPS from far end.
- c) Intelligent dry contact card: Use the monitoring function of the dry contact interface system to monitor and manage the power source of the UPS.

NOTE: Remove the cover before installing the optional accessories.

Intelligent Slot can be used together with RS232.

The operating instruction of the UPSilon2000 can be acquired from the CD.

As for the operating instructions of the intelligent USB card, SNMP card and dry contact card, please refer to the relative special instructions